

Győződjön meg róla, hogy a kék csapágyazású tengelycsapágyak helyesen helyezkedjenek el. A csapágyak a külső helyzetben vannak. Lásd alább:

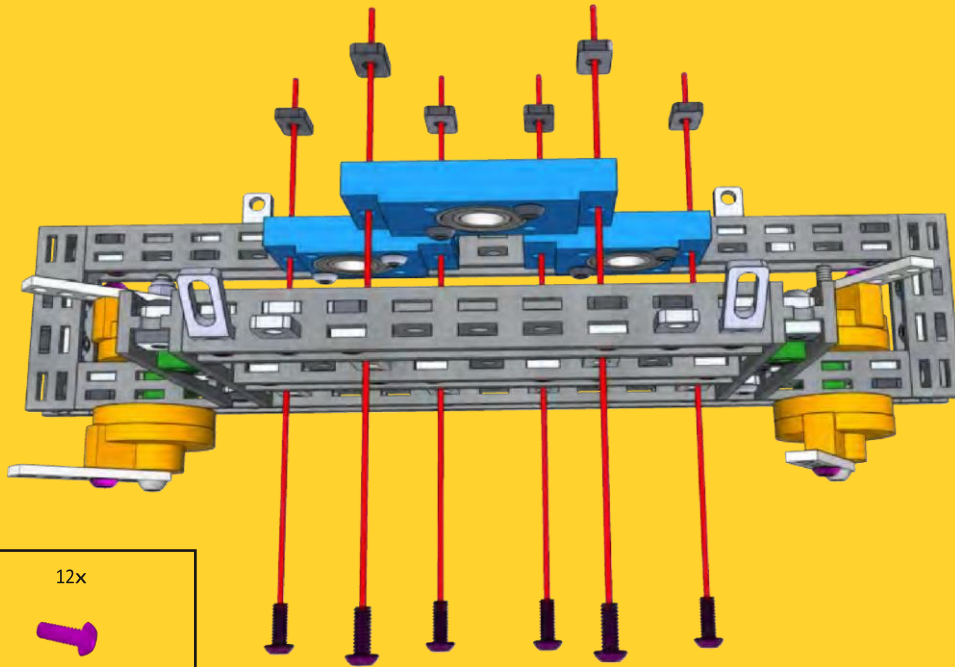

- 12x
-  M3x8 mm Csavar
- 12x
-  Anya M3 6x10

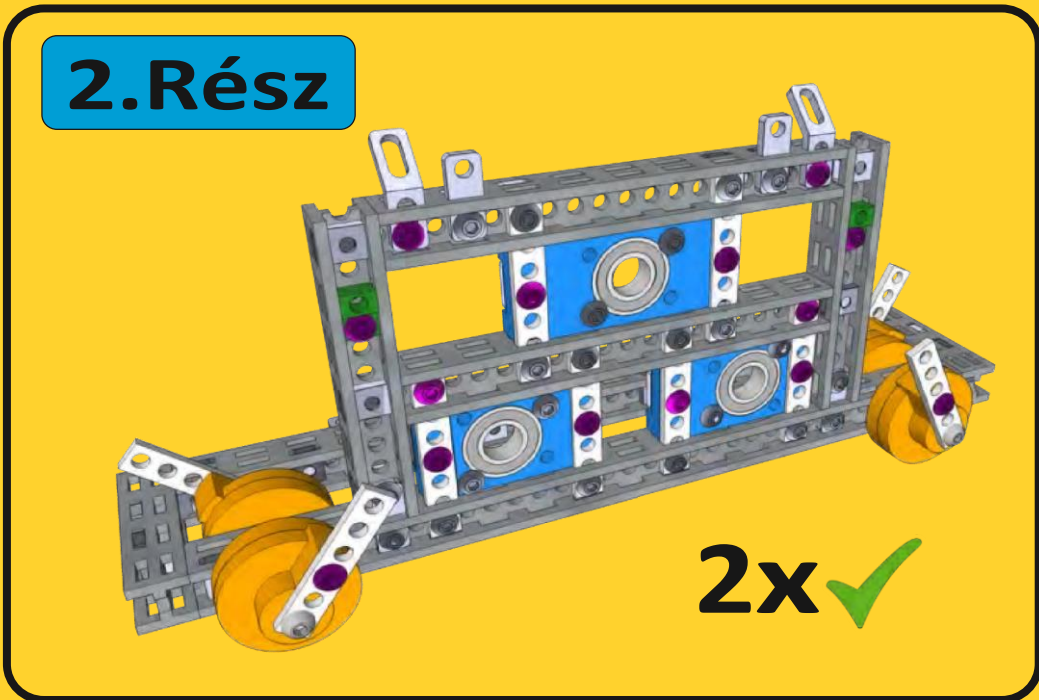
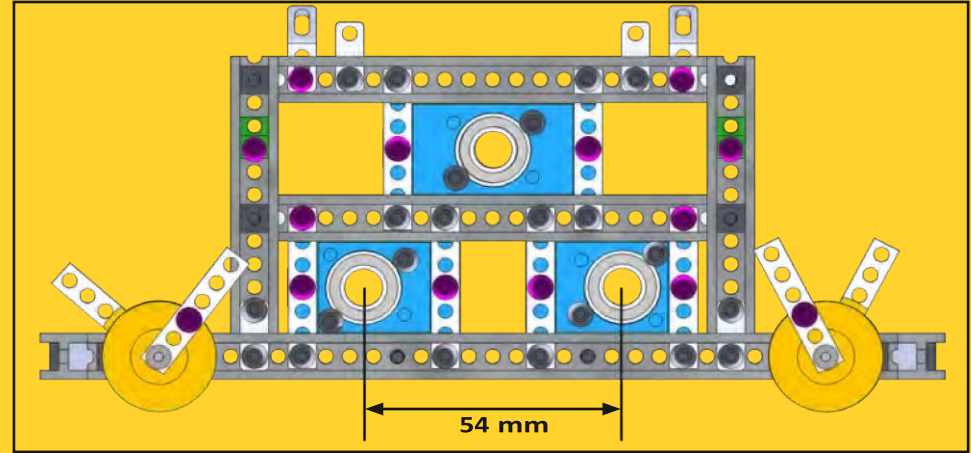
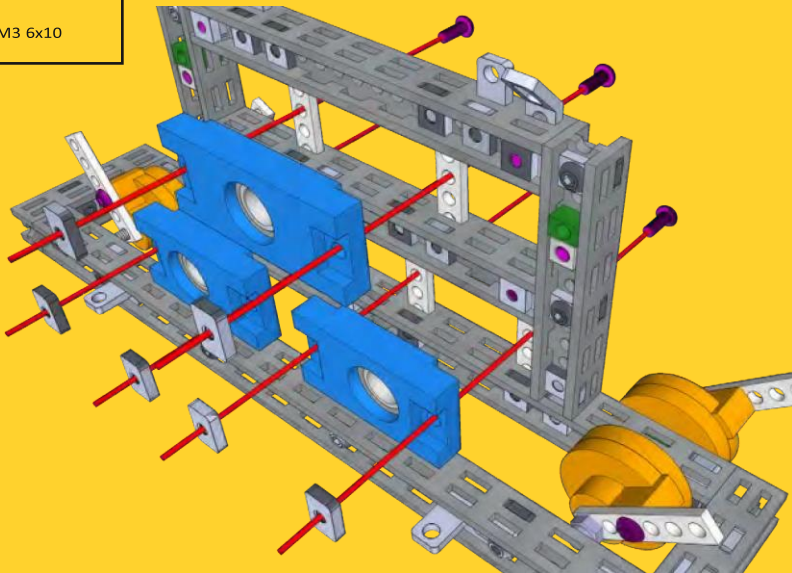

# 3. Rész

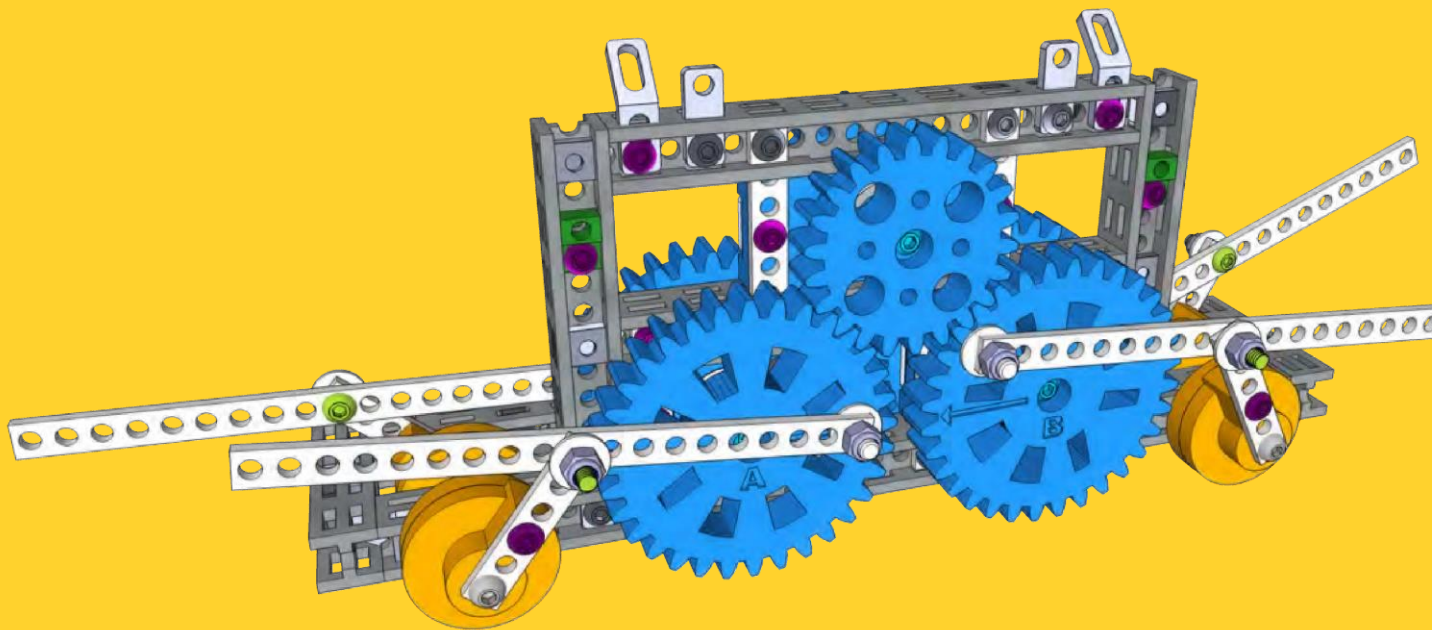

2x

8x



M3x8 mm Csavar

8x



M3x12 mm Csavar

6x



M3x25 mm Csavar

8x



M3-6LAPF 12 mm Csavar

16x



Záróanya M3

16x



Alátét 9/0.8mm M3

1x



Fém anya M3

2x



Motorcsatlakozó 6 mm

6x



Anya M3 6x10

2x



Felső fogaskerék A

2x



Felső fogaskerék B

2x



Alsó fogaskerék A

2x



Alsó fogaskerék B

2x



Alsó fogaskerék C

2x



Alsó fogaskerék D

8x



9.5 cm/19-Lyukú szalagkonzol

A fém anya segít a csavart a fogaskerékbe nyomni.

1

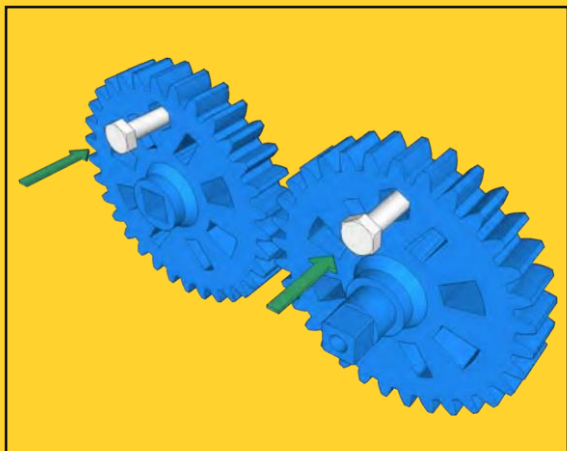

1

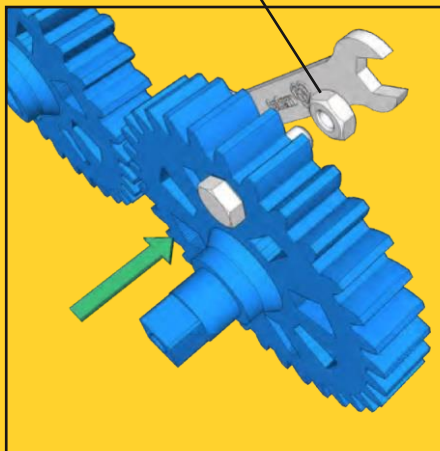

2

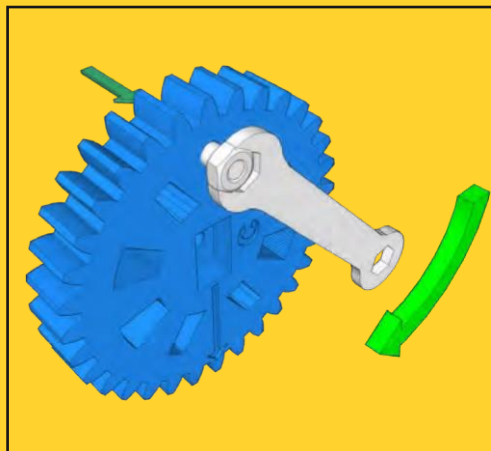

3

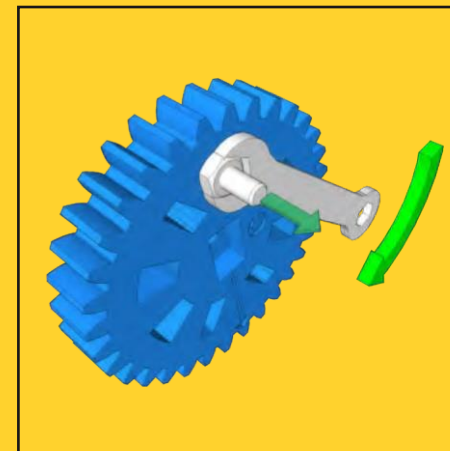

4

A csavarokat olyan mélyen kell behelyezni, amennyire lehetséges (min. 2 mm).

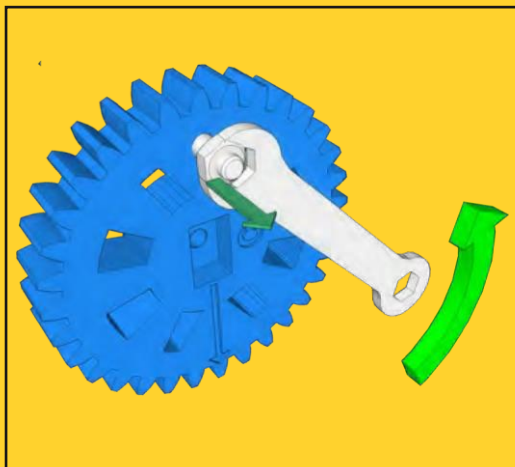



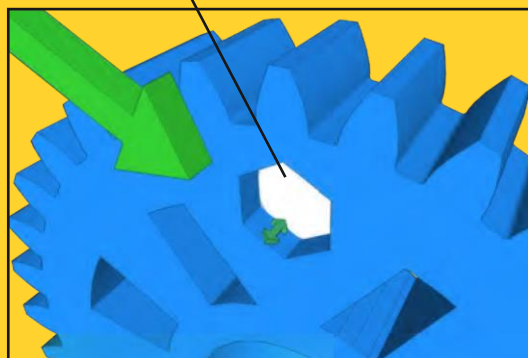



5



6



2x

8x	1x	2x	2x	2x	2x
					
M3-6LAPF 12 mm Csavar	Fém anya M3	Alsó fogaskerék A	Alsó fogaskerék B	Alsó fogaskerék C	Alsó fogaskerék D



2

2x



Anya M3 6x10

2x



M3x25 mm Csavar

2x



Alsó fogaskerék A

2x



Alsó fogaskerék C

2x



2.Rész

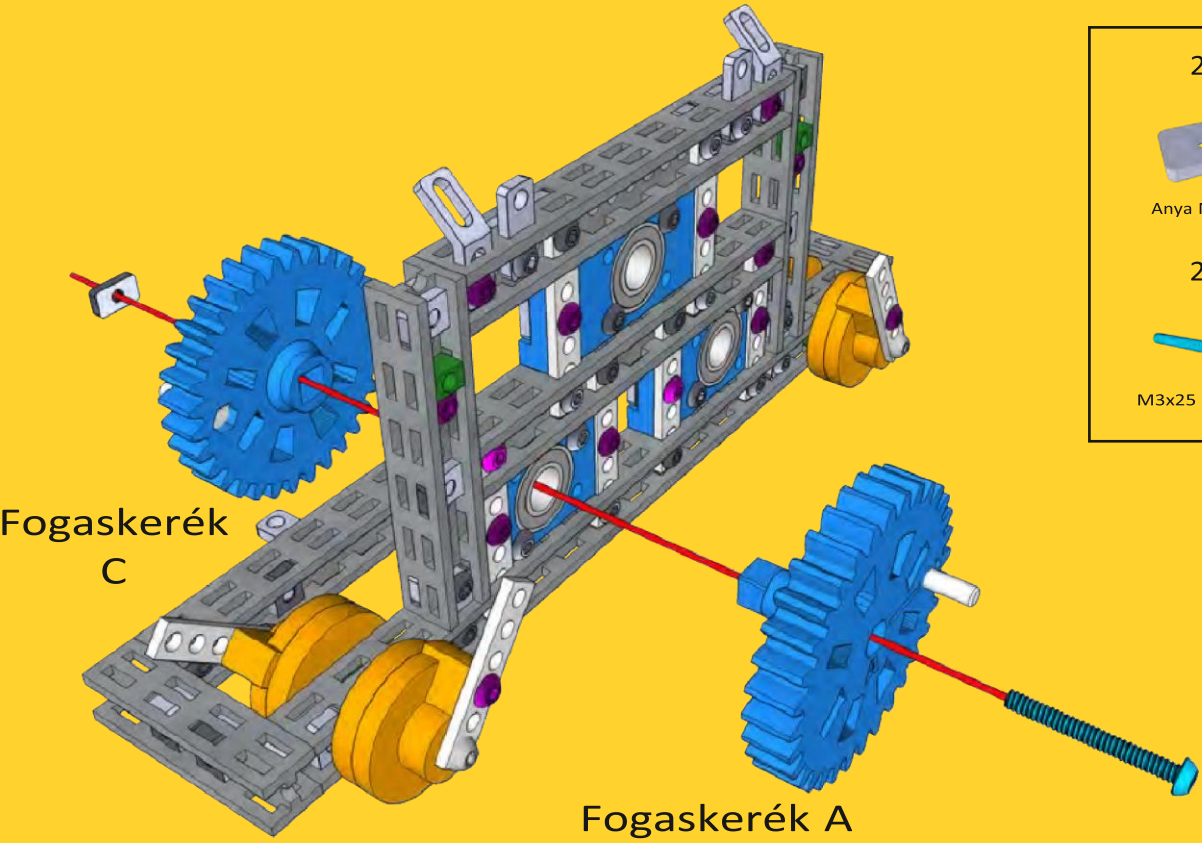

Csavarok (piros) átlósan szemben lesznek egymással.

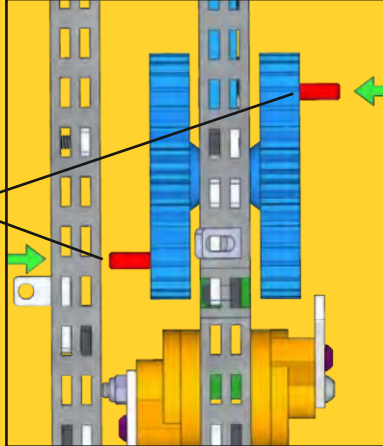

Az "A" és "C" betűvel jelöltük a fogaskerekeket, az alkatrészek közepén.

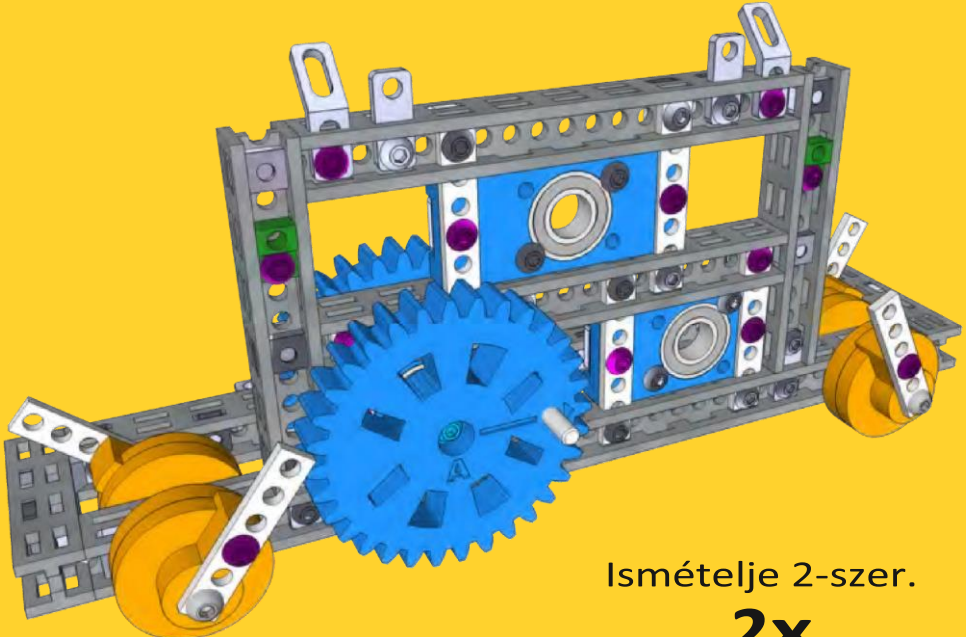
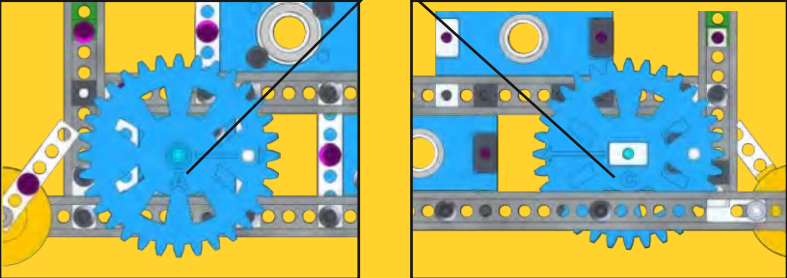

Ismételje 2-szer.  
**2x**



Az "A", "B", "C", "D" betűk jelölik a fogaskerekeket.

3

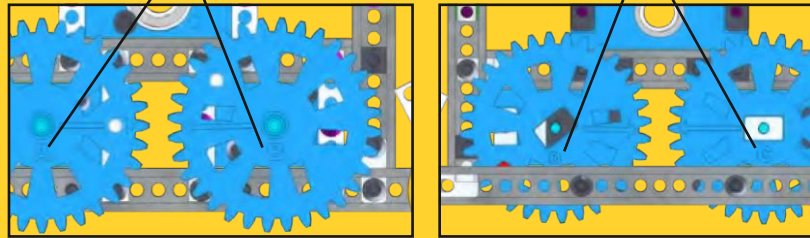

Fogaskerék D

Fogaskerék B

Csavarok (piros) átlósan szemben lesznek egymással.

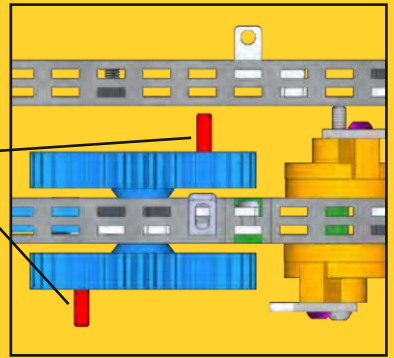

2x



Anyá M3 6x10

2x



M3x25 mm Csavar

2x



Alsó fogaskerék B

2x



Alsó fogaskerék D

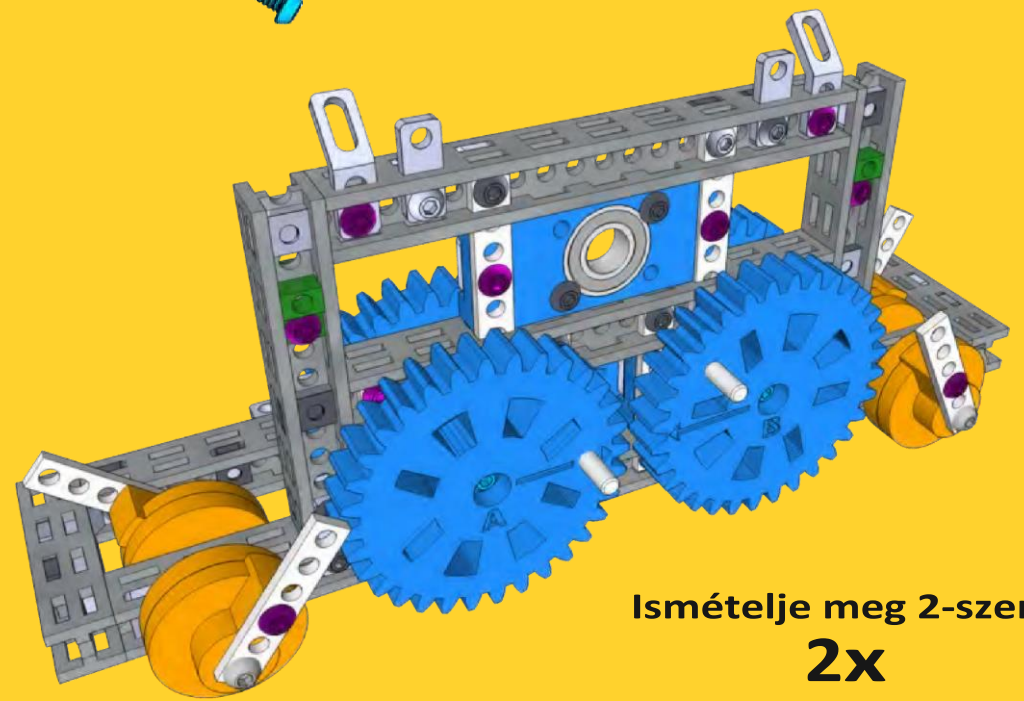

Ismételje meg 2-szer.  
**2x**

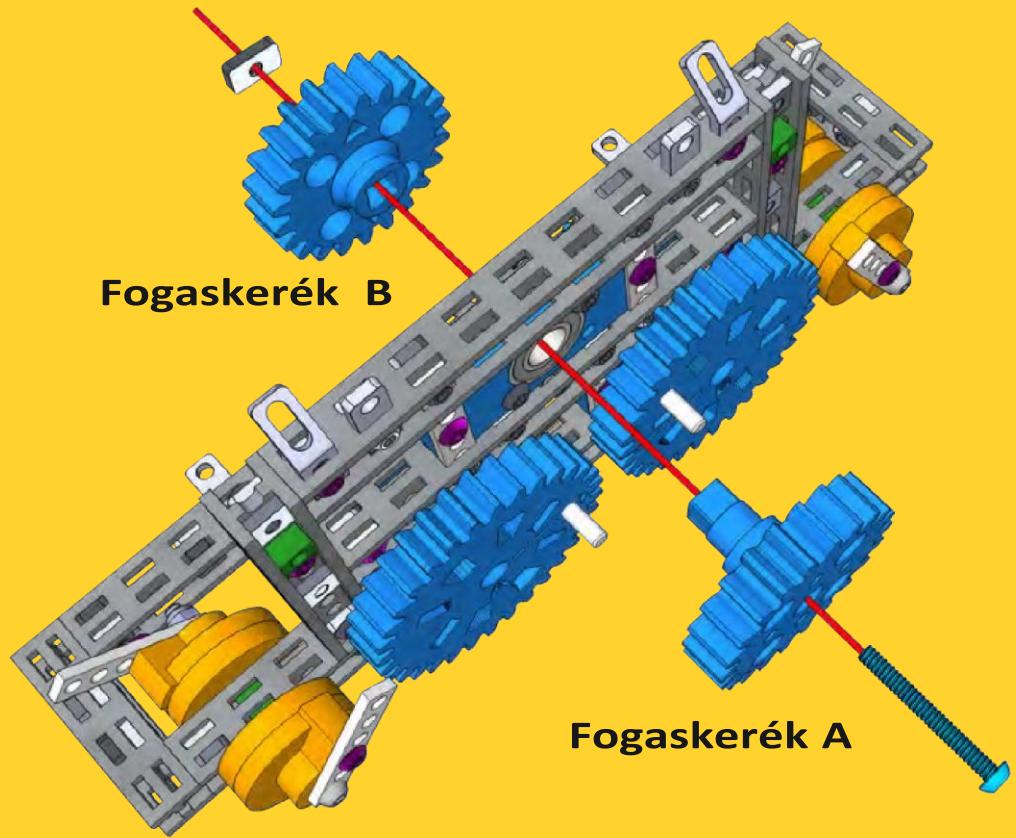

Fogaskerék B

Fogaskerék A

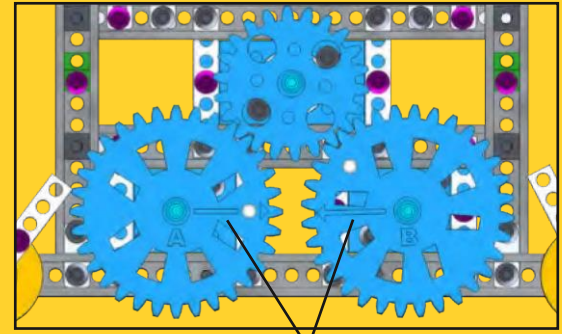

A nyilaknak mindkét oldalon egymásra kell mutatniuk.

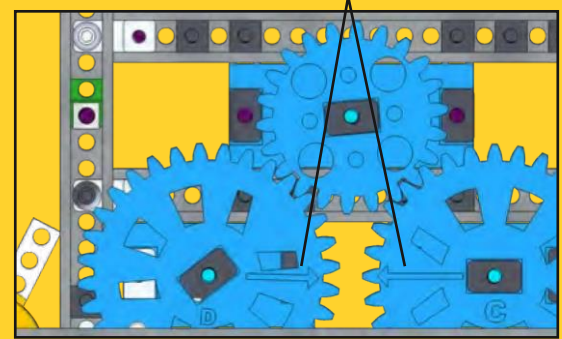

A háromszögeknek mindkét felső fogaskeréknél ugyanabba az irányba kell mutatniuk.

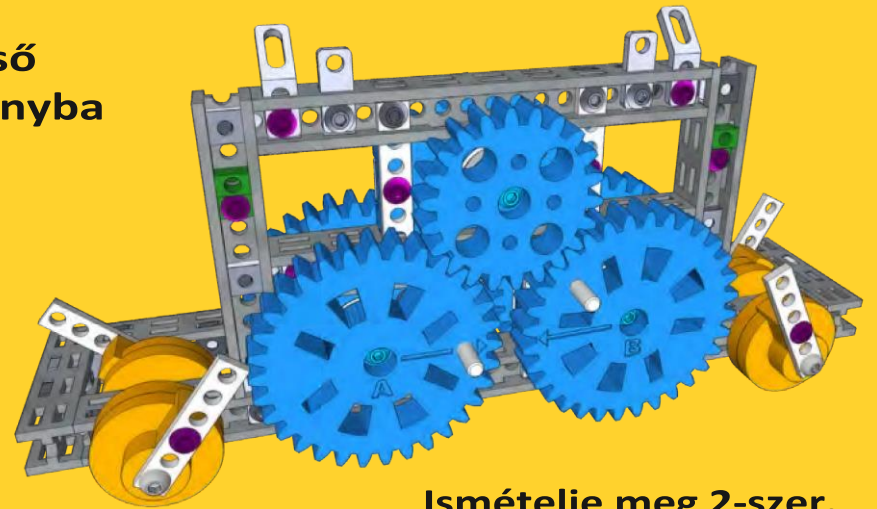
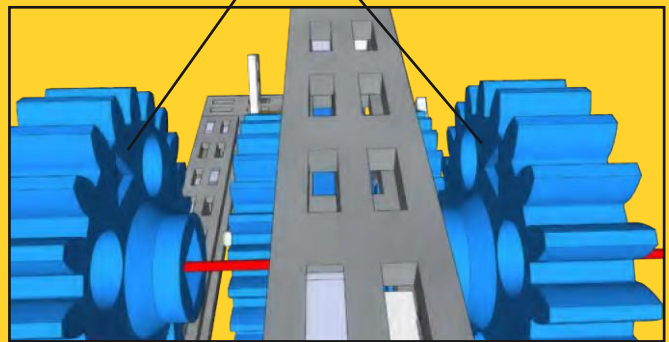
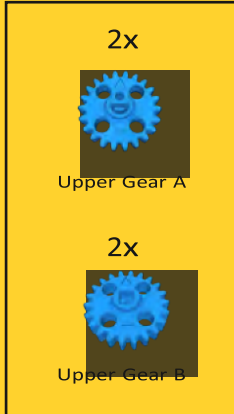
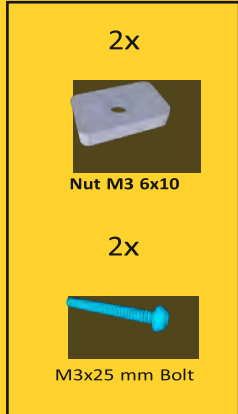

Ismételje meg 2-szer.

2x



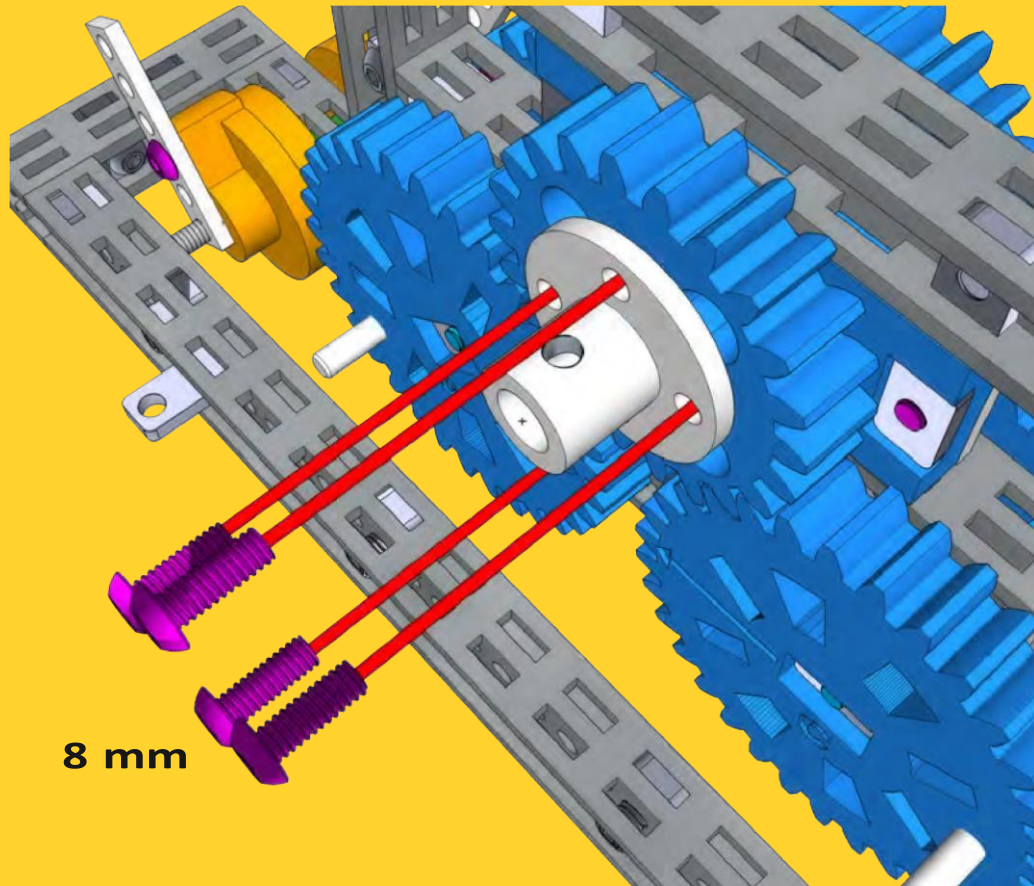

8 mm

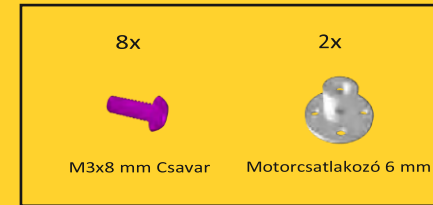

5

Ismételje meg 2-szer.

2x

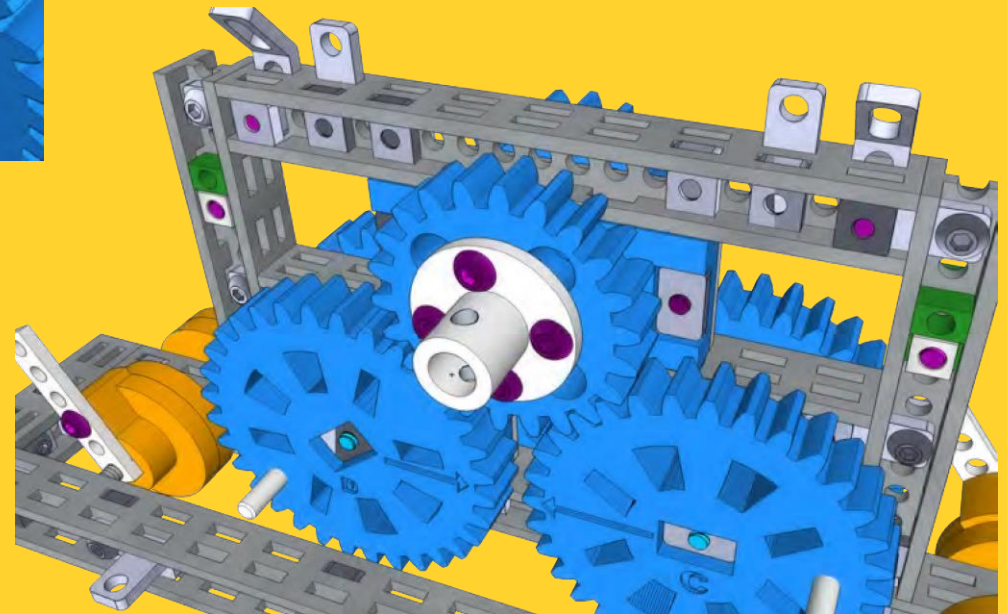



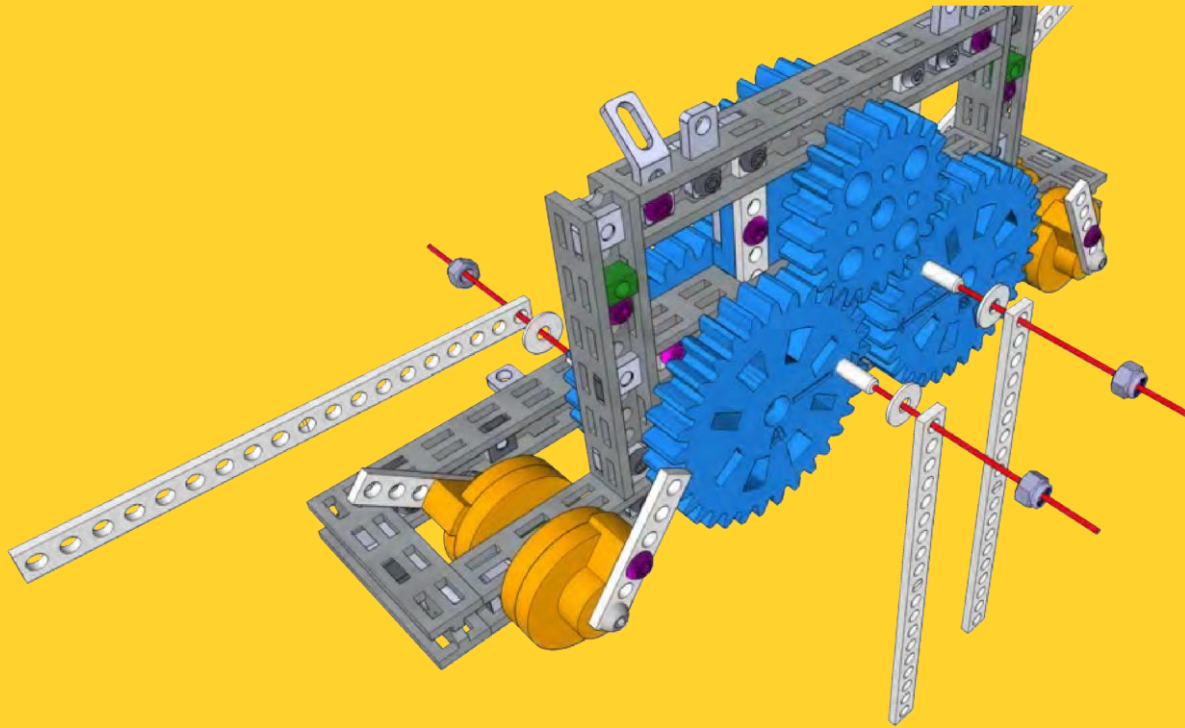

- 8x  
  
Záróanya M3
- 8x  
  
Alátét 9/0.8mm M3
- 8x  
  
9.5 cm/19-Lyukú szalagkonzol

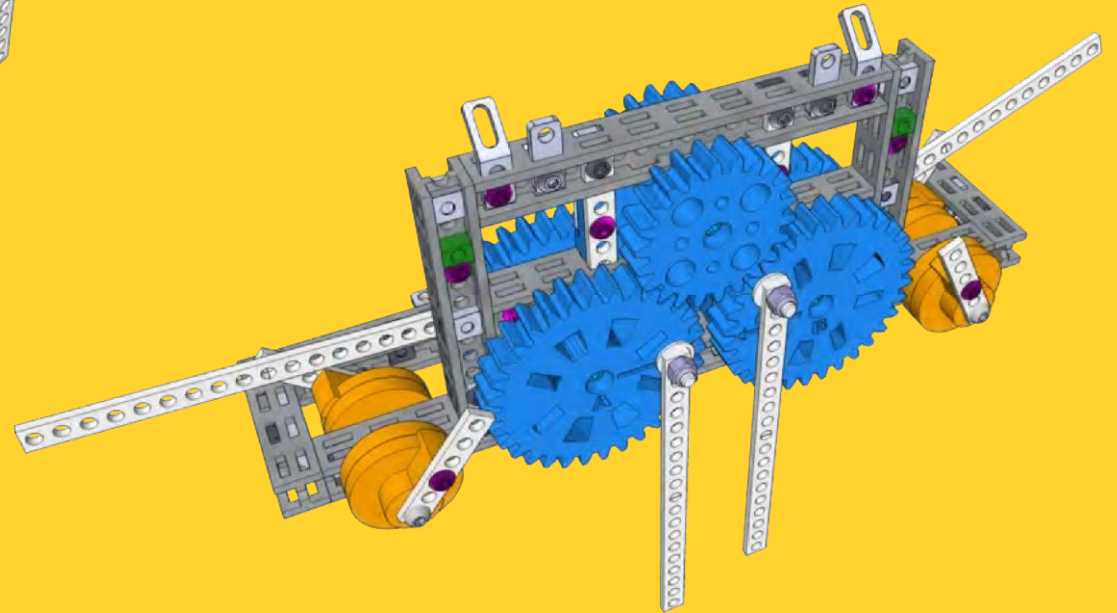
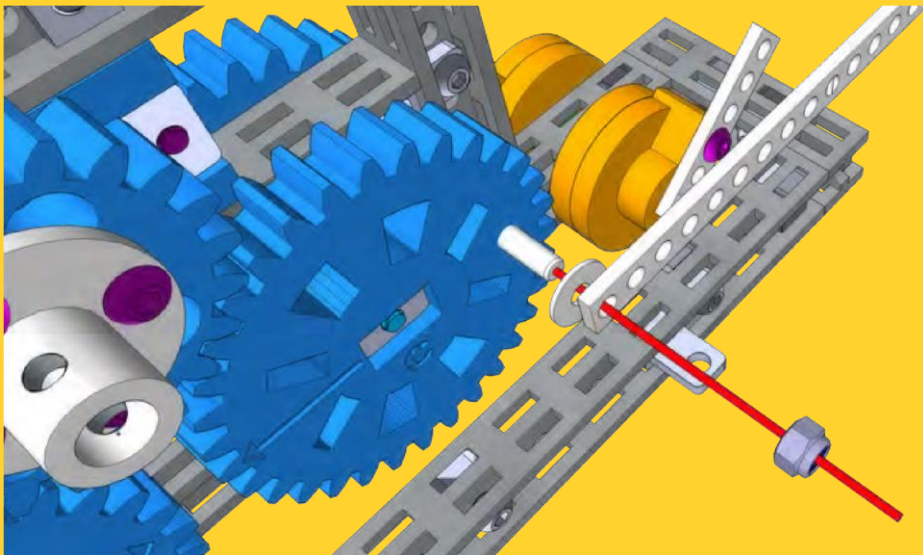

Ismételje meg 2-szer.

2x



Szerelje fel az  
M3x12 csavart a  
9,5 cm-es  
szalagtartó  
középső lyukába.

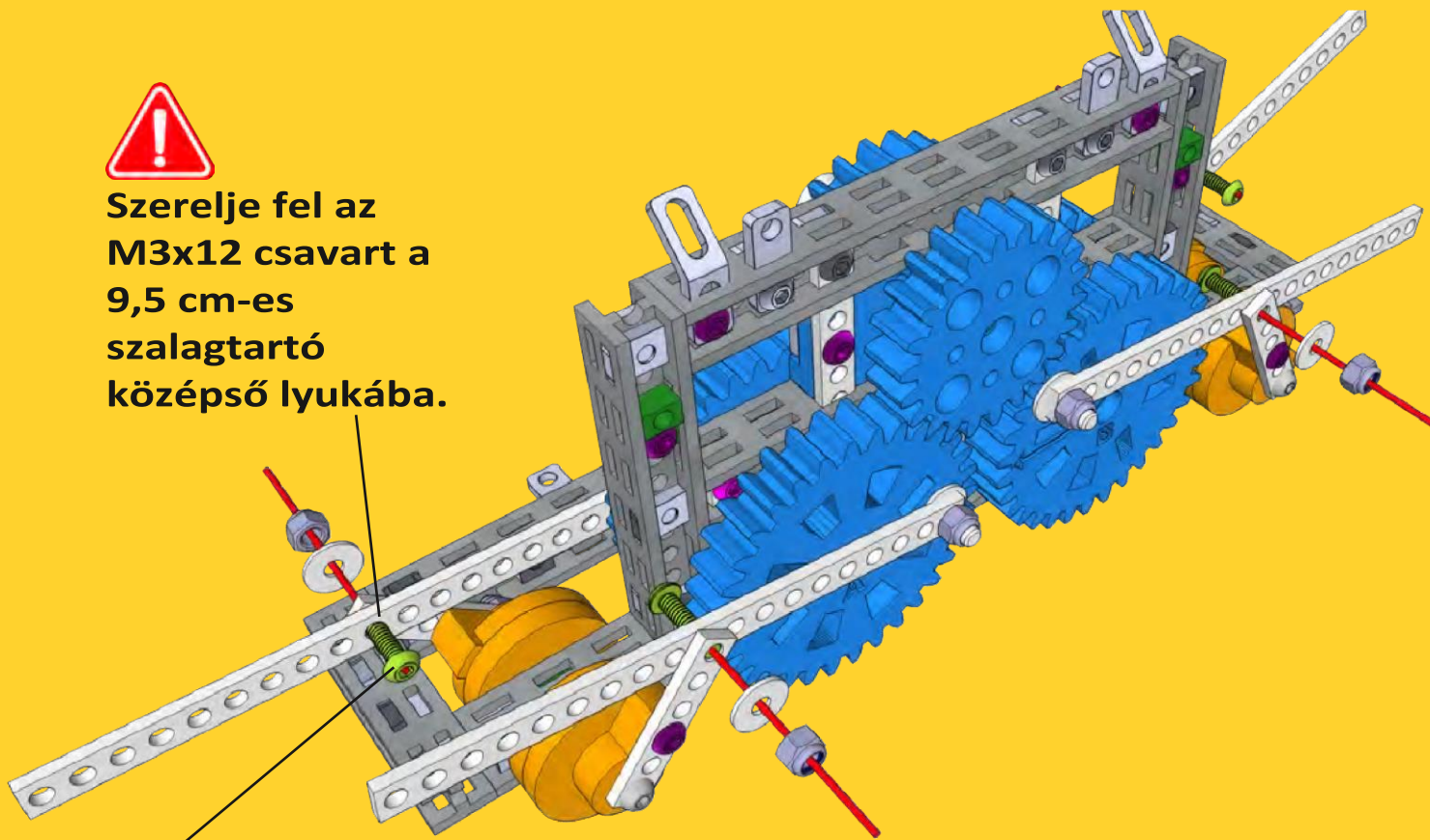

12 mm

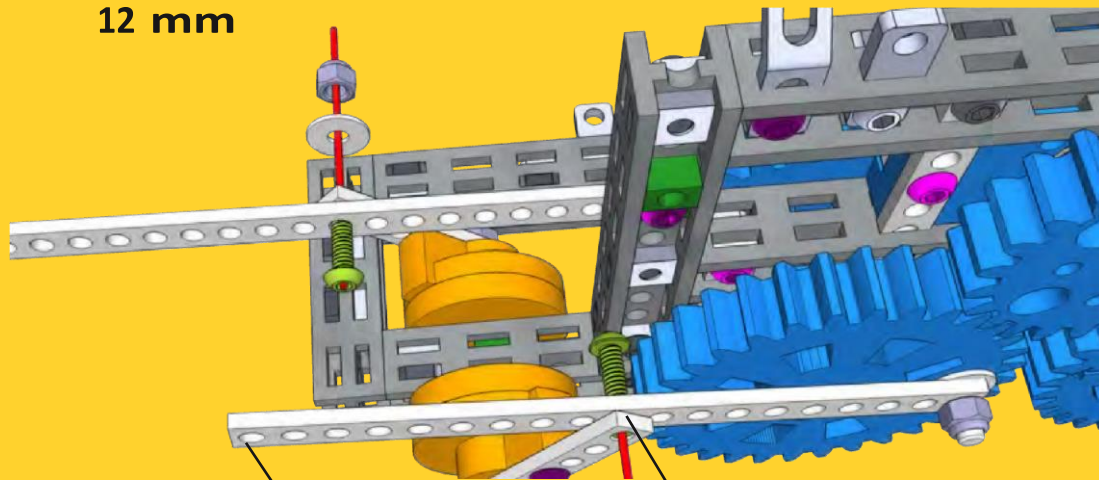

Lyuk #1

Lyuk #10

8x



Záróanya M3

8x



Alátét 9/0.8mm M3

8x



M3x12 mm Csavar

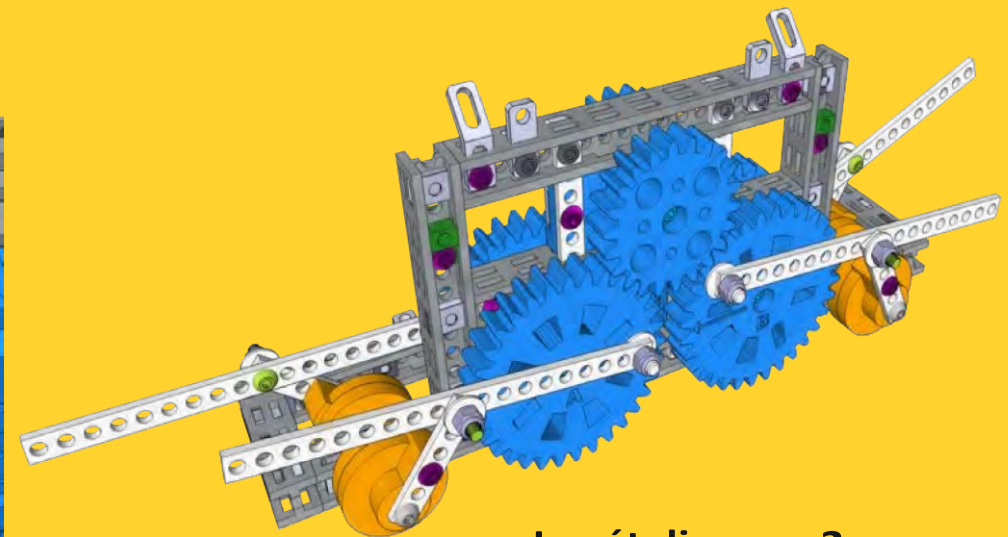

Ismételje meg 2-szer.

2x



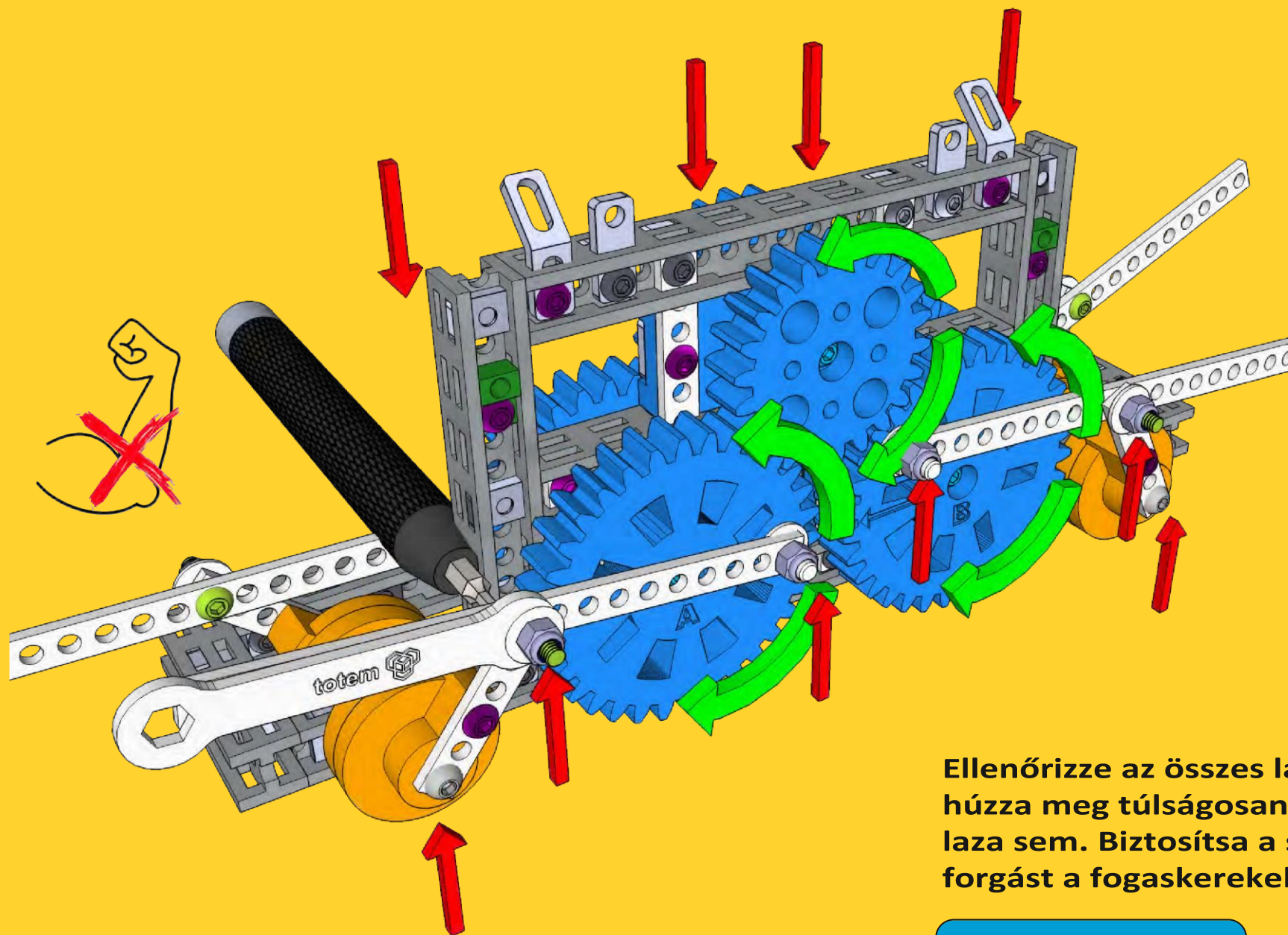

Ellenőrizze az összes láncszemet, ne húzza meg túlságosan. Nem legyen túl laza sem. Biztosítsa a sima forgást a fogaskerekek forgatásakor.

**3.Rész**





# 4.Rész

4 x 1A.Rész

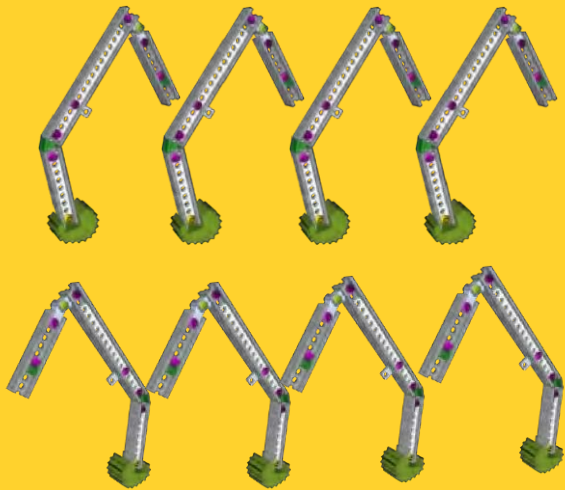

4 x 1B.Rész

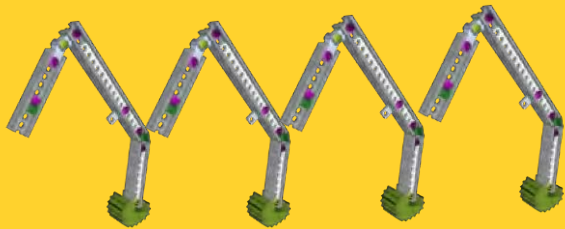

+

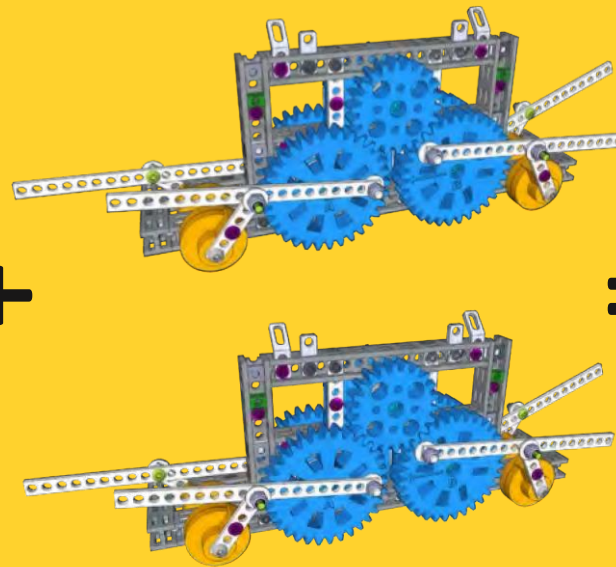

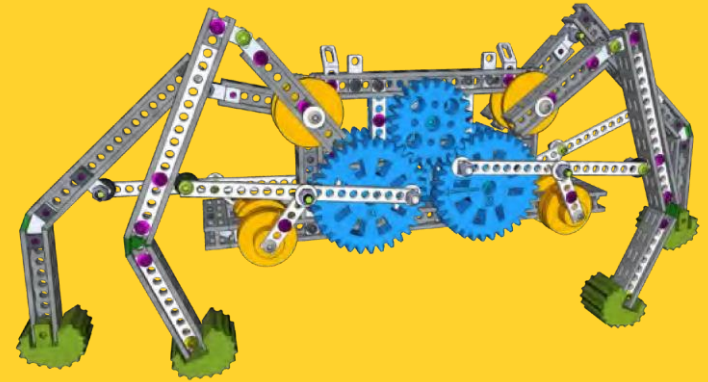

=



2 x 3.Rész

2 x 4.Rész

8x	4x	12x	8x	16x	8x
					
M3x12 mm Csavar	M3x45 mm Csavar	Záróanya M3	Felső kar alátét	Műa.alátét 8/1 mm M3	Alátét 9/0.8mm M3

**1B.Rész**

**1A.Rész**

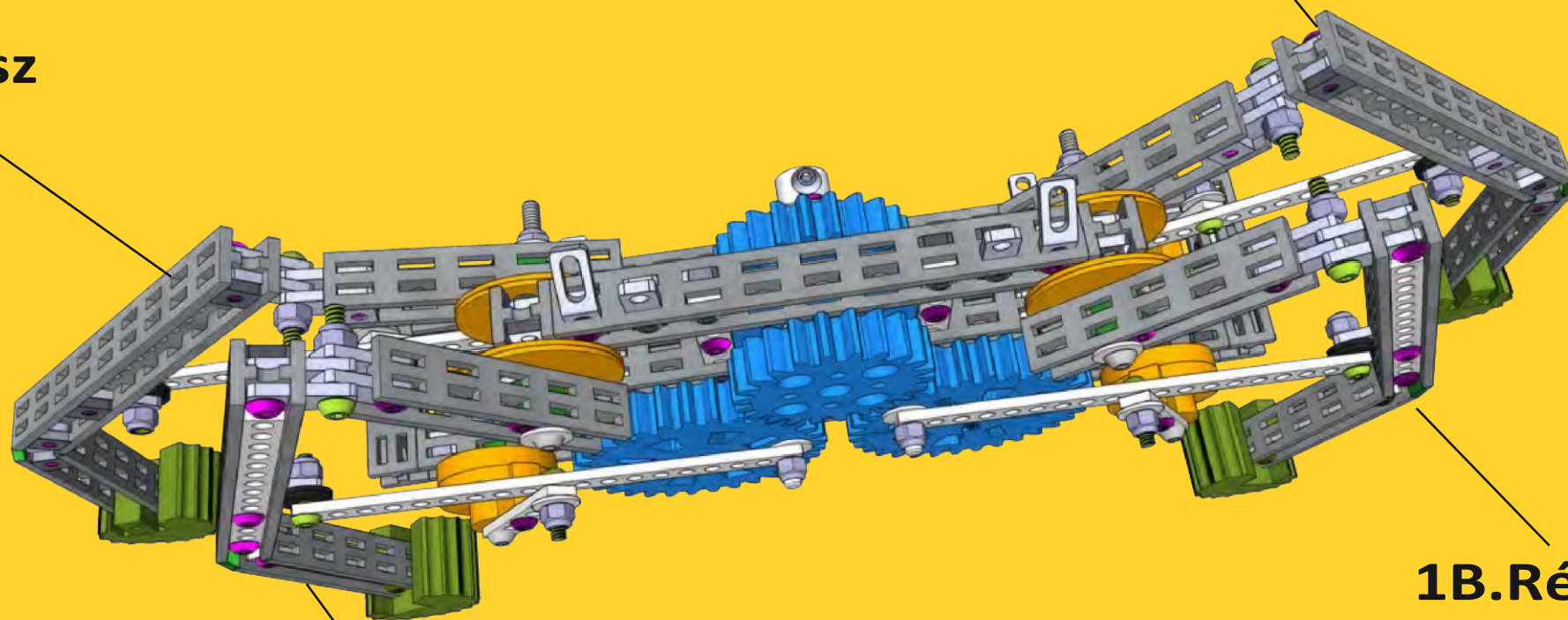

**1B.Rész**

**1A.Rész**

1B.Rész

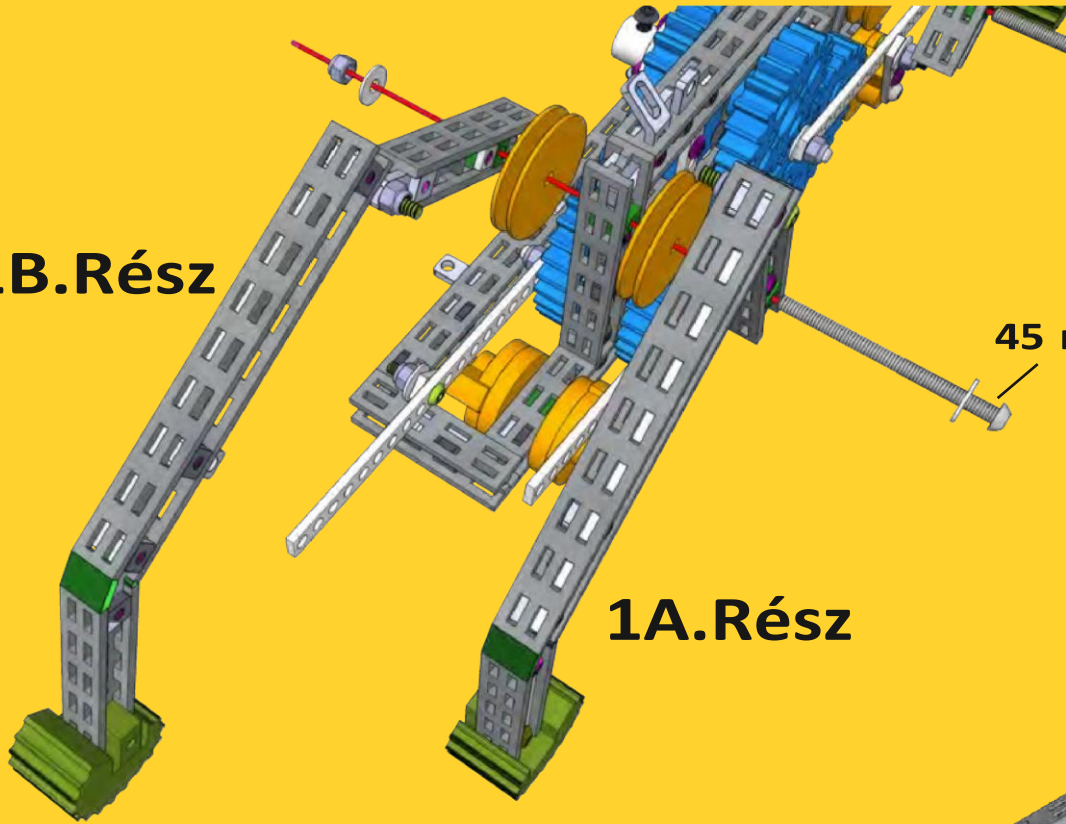

45 mm

1A.Rész

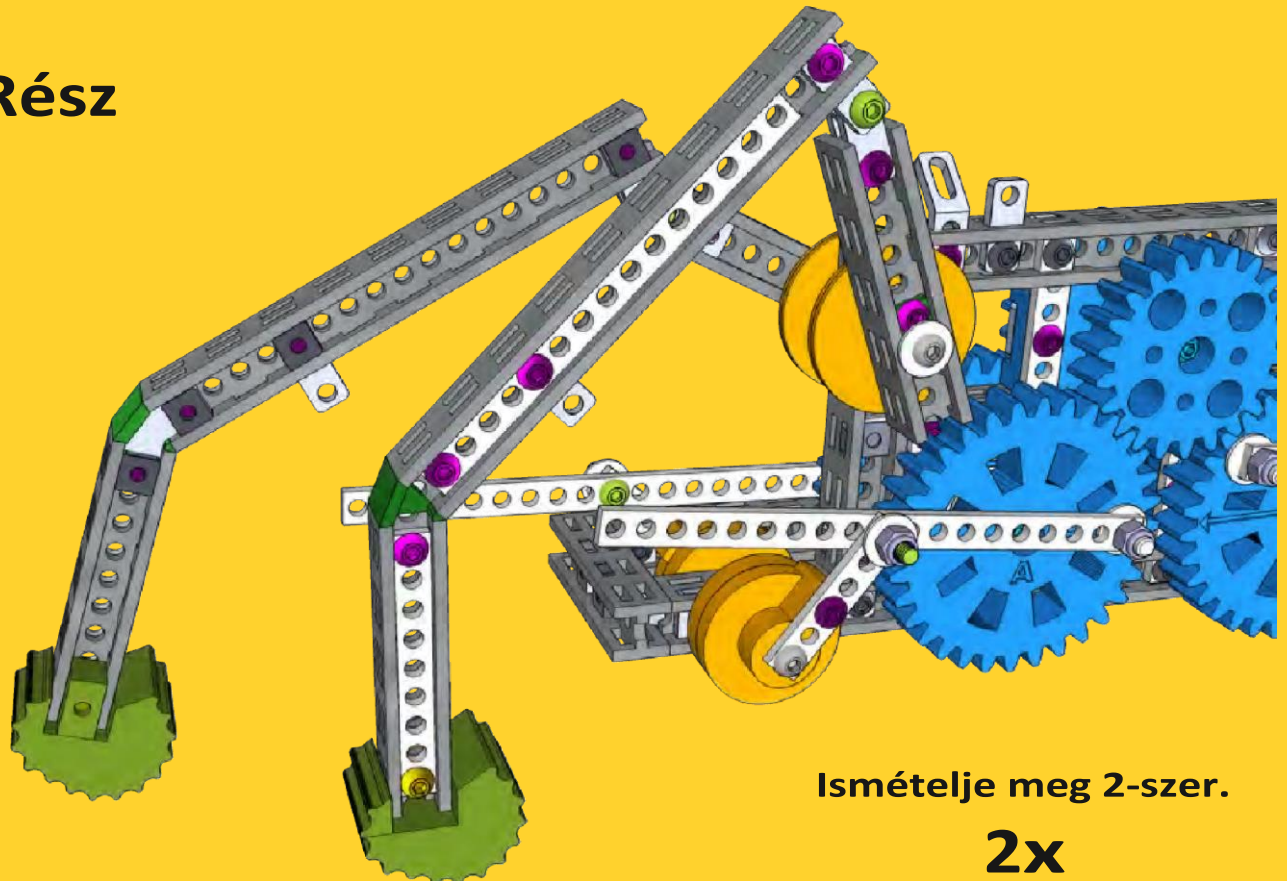

Ismételje meg 2-szer.

2x

2x	4x
	
Záróanya M3	Felső kar alátét
2x	4x
	
M3x45 mm Csavar	Alátét 9/0.8mm M3



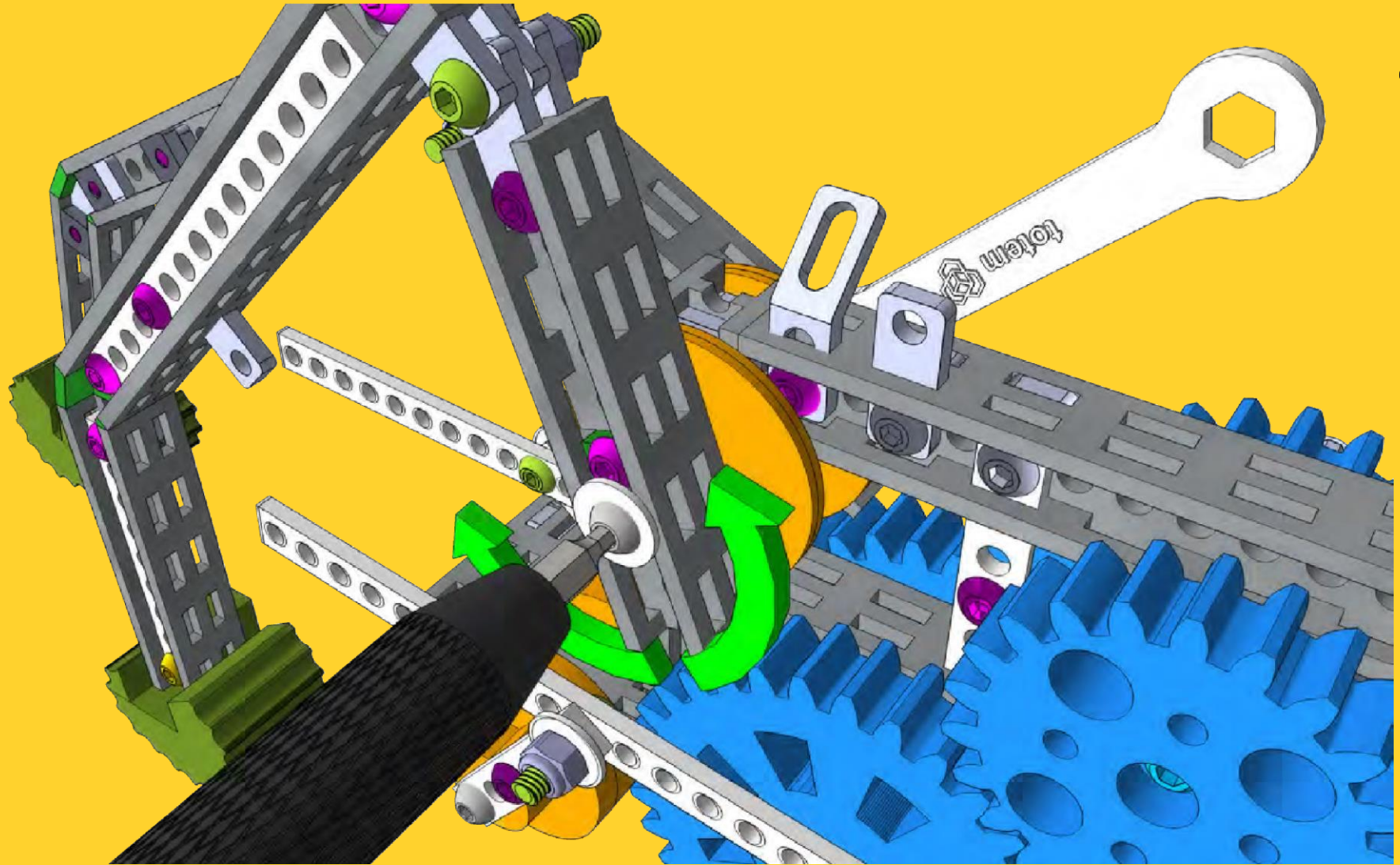

Nem szabad túlhúzni.



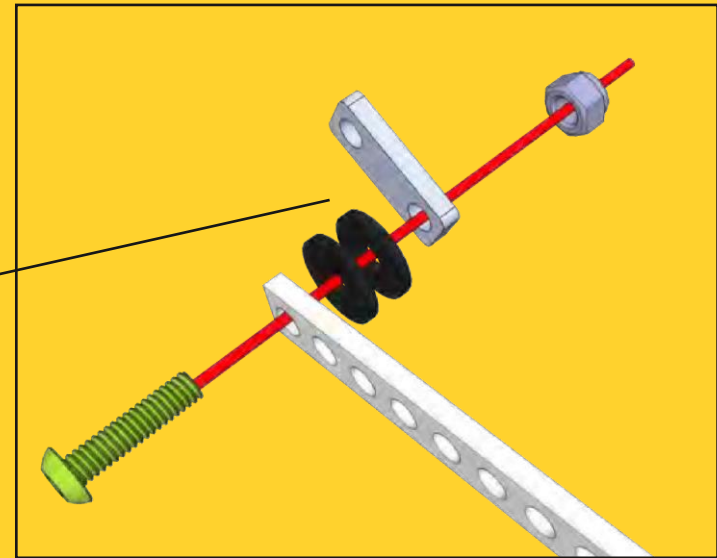
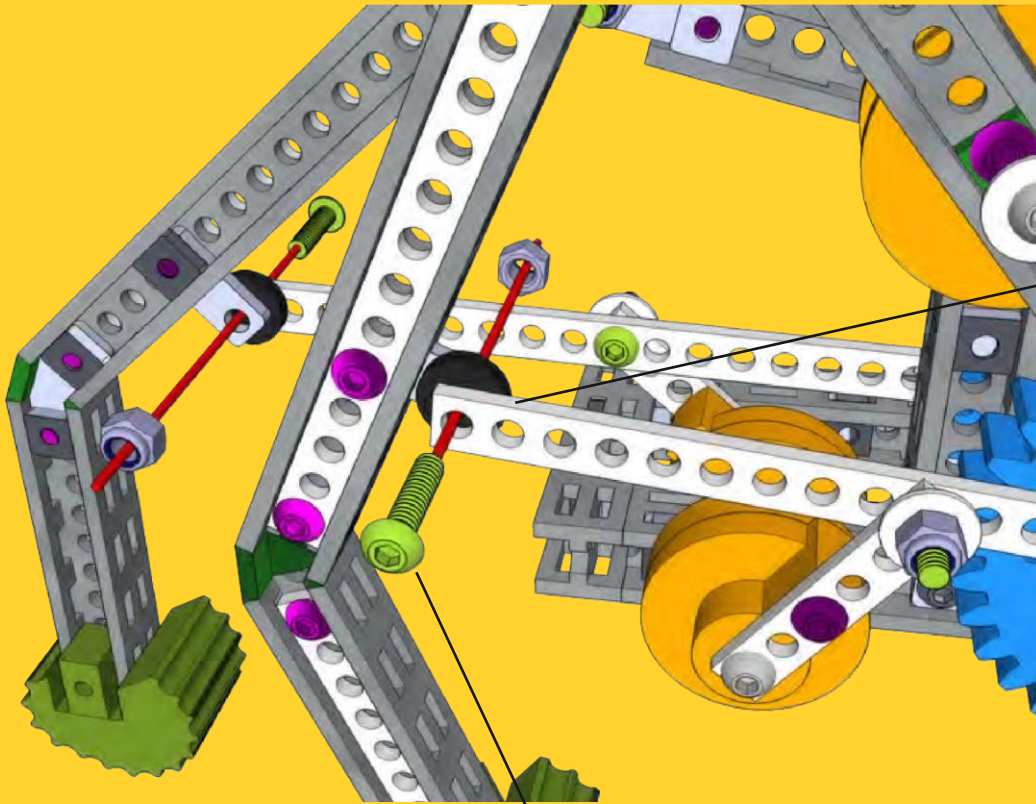



3

12 mm

Ismételje meg 2-szer.  
2x

- 4x  
  
M3x12 mm Csavar
- 4x  
  
Záróanya M3
- 8x  
  
Műa. alátét 8/1 mm M3

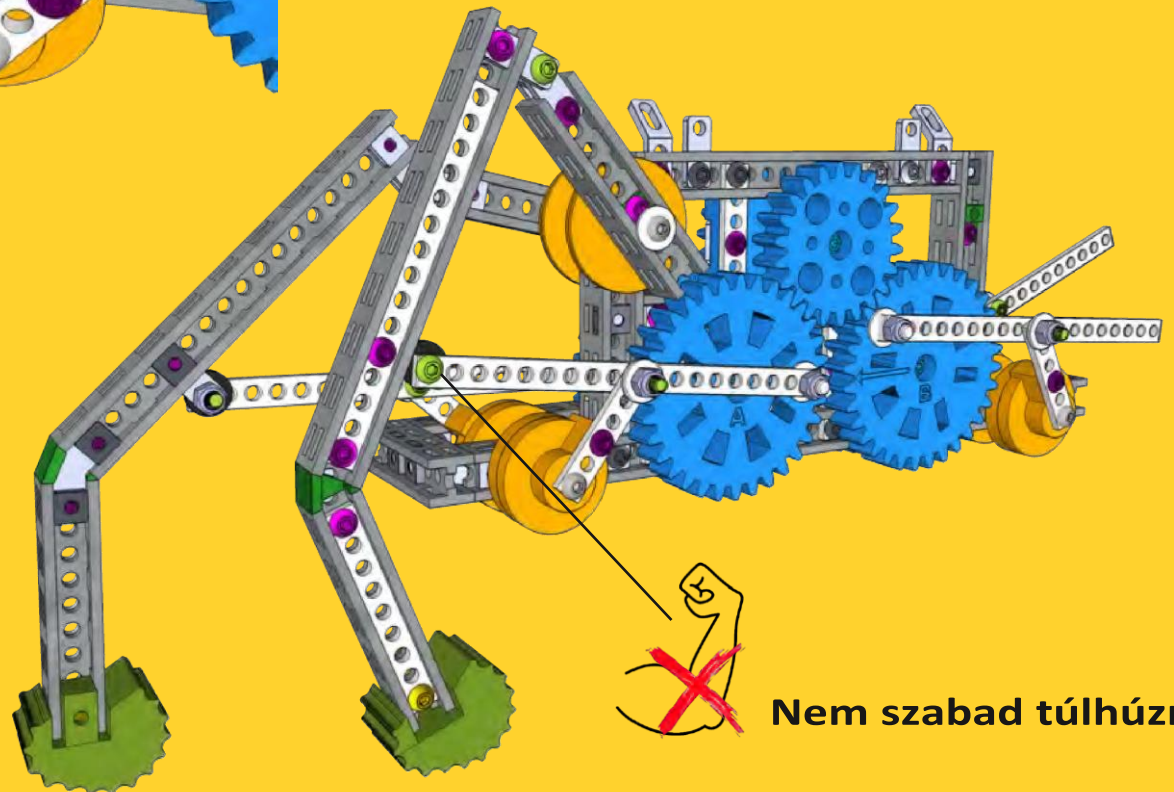

Nem szabad túlhúzni.



1A.Rész

1B.Rész

45 mm

Ismételje meg 2-szer.

2x

- 2x  
  
Záróanya M3
- 2x  
  
M3x45 mm Csavar
- 4x  
  
Felső kar alátét
- 4x  
  
Alátét 9/0.8mm M3

4

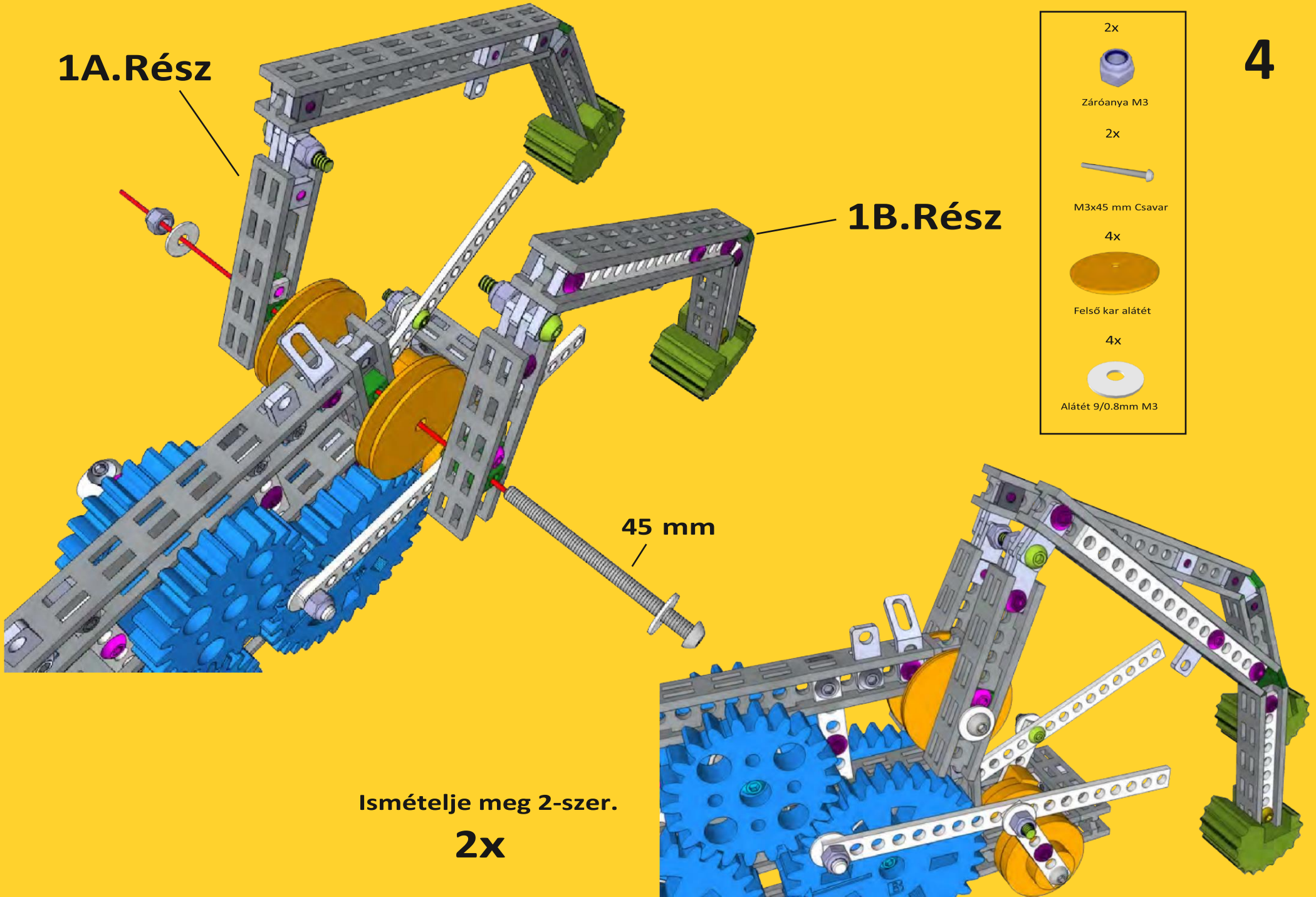



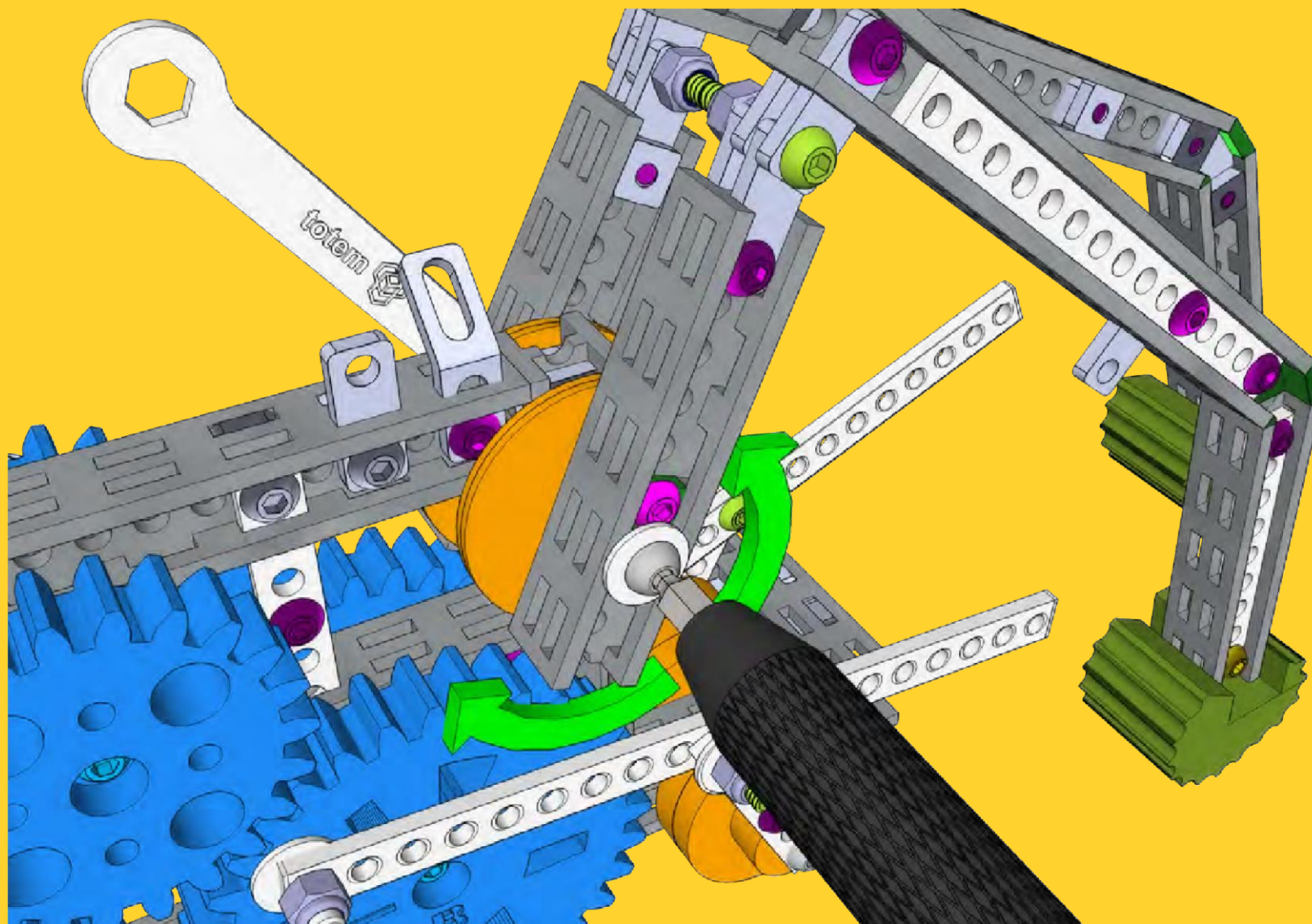



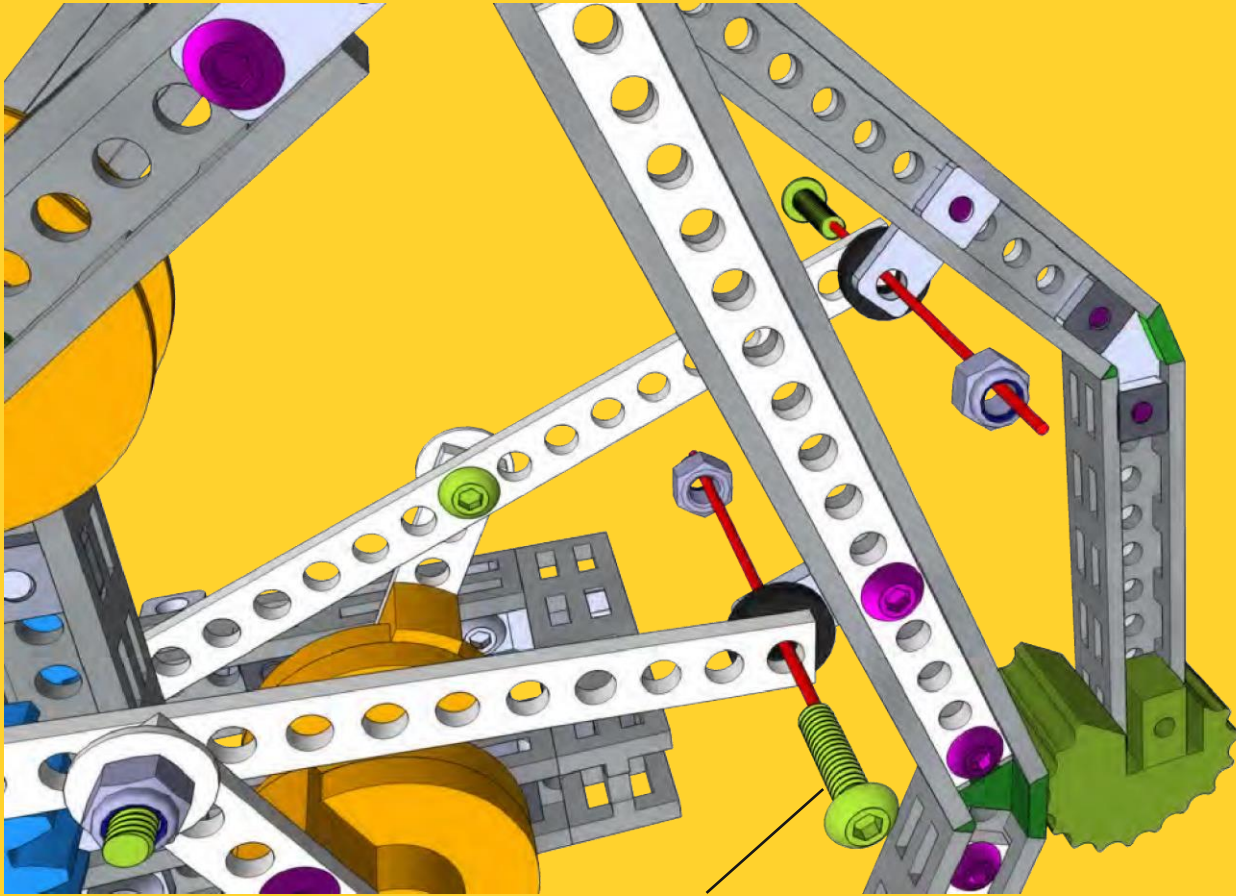

Nem szabad túlhúzni.





- 4x  
  
M3x12 mm Csavar
- 4x  
  
Záróanya M3
- 8x  
  
Műa.alátét 8/1 mm M3

12 mm

Nem szabad túlhúzni.

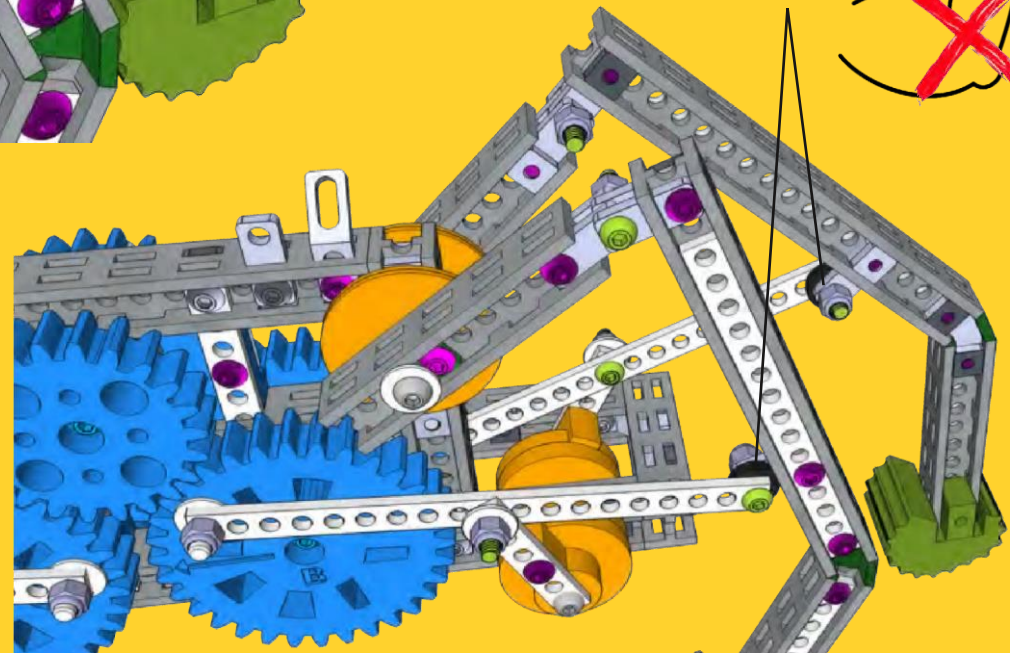

Ismételje meg 2-szer.

2x



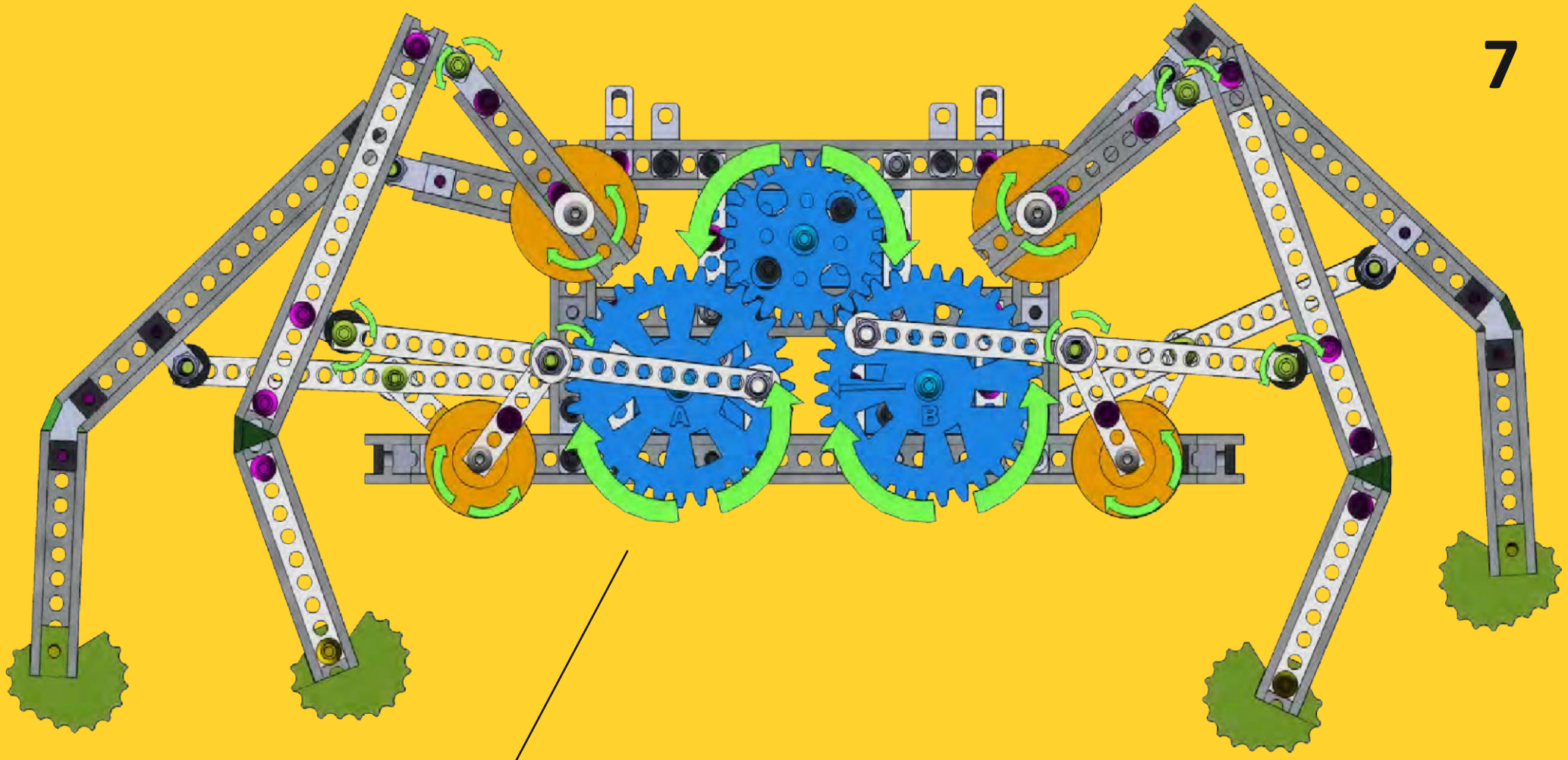

Próbálja meg a fogaskerekeket pörgetni a kezével, és ellenőrizze, hogy a mozgásuk egyenletes-e. A lábak és a láncszemek nem lehetnek túlságosan ingatagok.

# 4. Rész





# 5. Rész

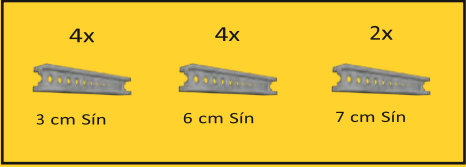
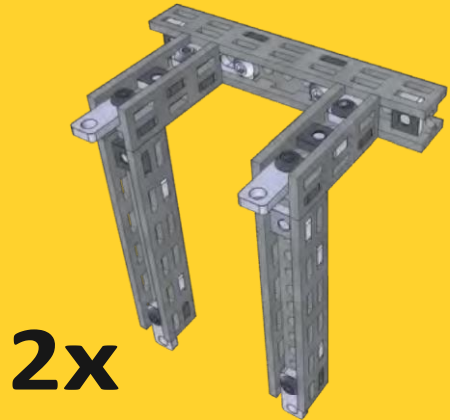

1

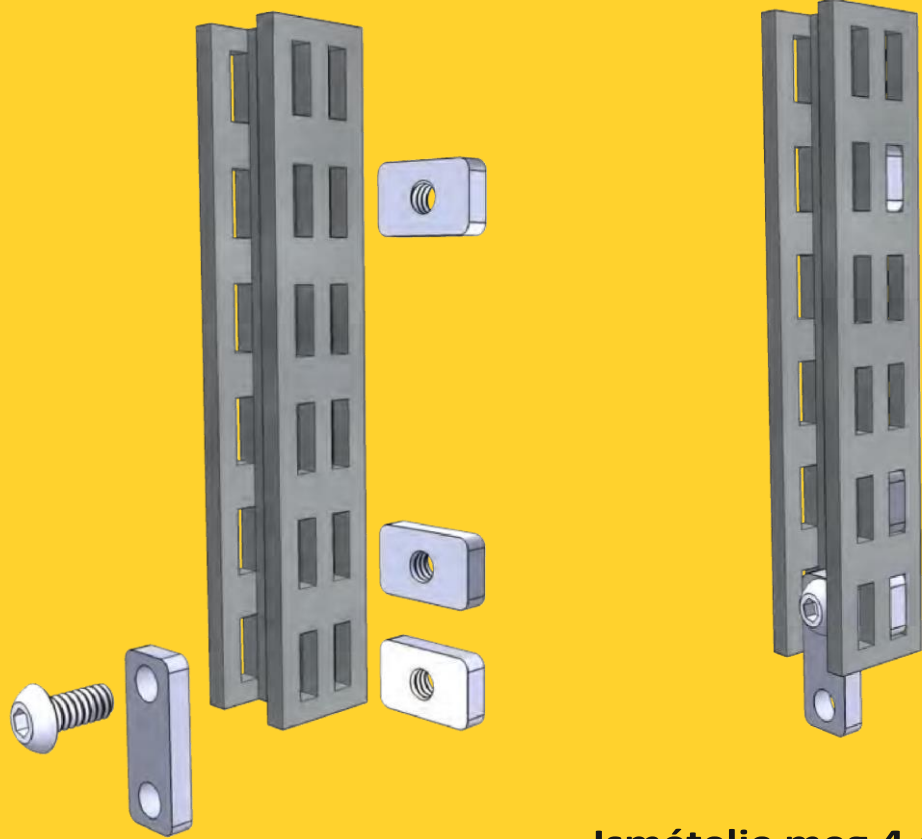

Ismételje meg 4-szer.  
**4x**

2

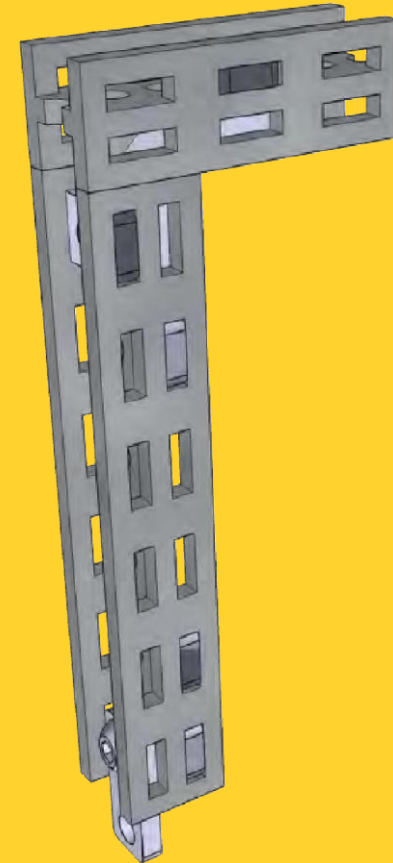
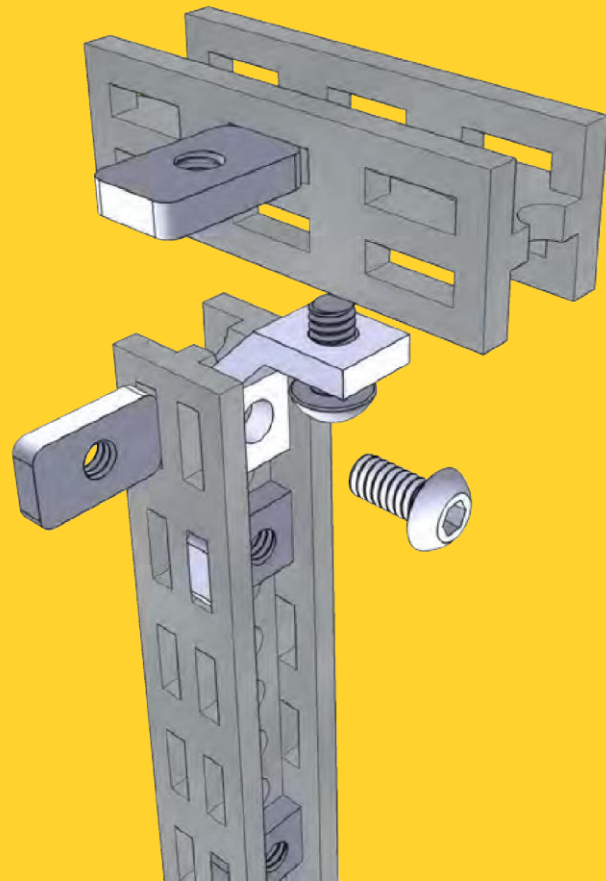

8x	8x	4x	4x
			
M3x6 mm Csavar	Anyá M3 6x10	C-Konzol	3 cm Sín

Ismételje meg 4-szer.

**4x**



3

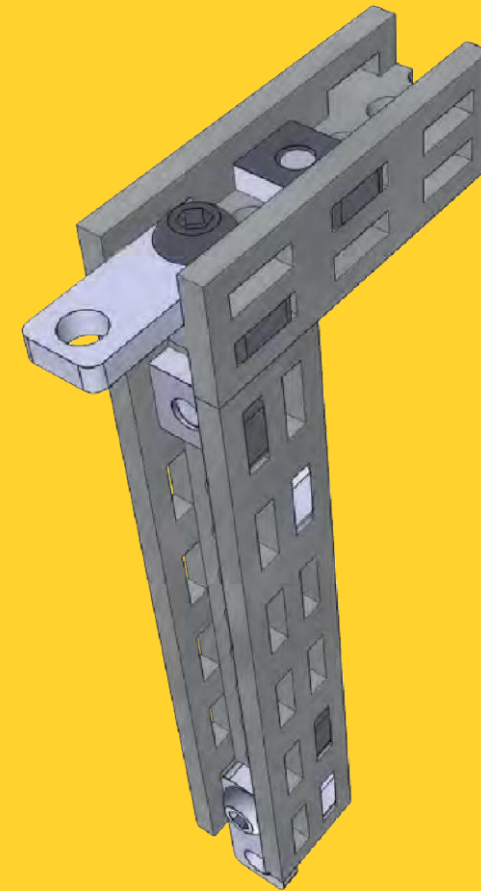
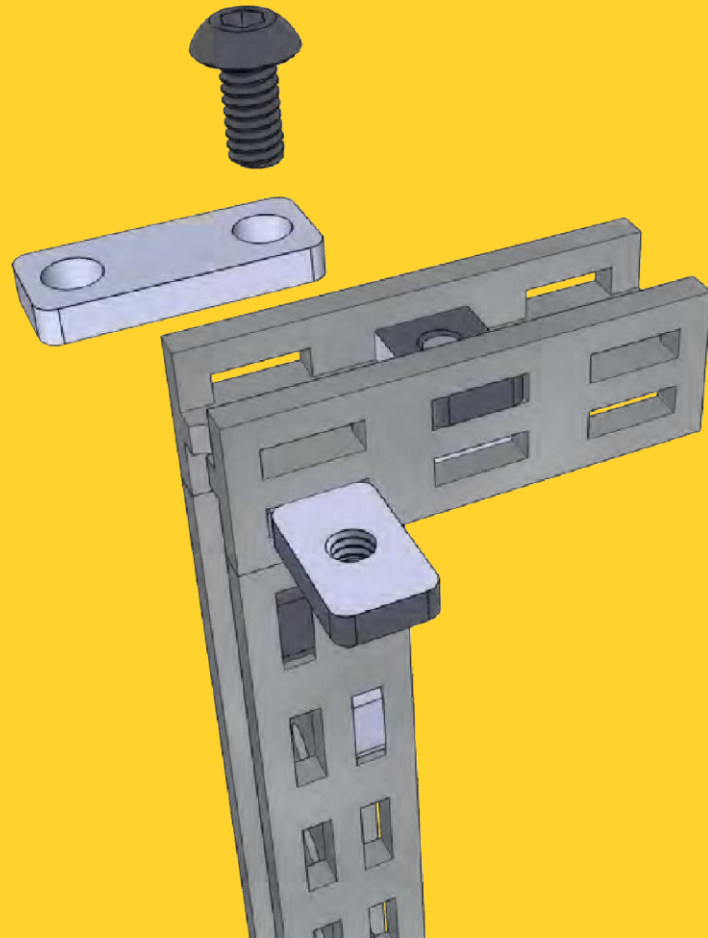

4x	4x	4x
		
M3x6 mm Csavar	Anya M3 6x10	2-Lyukú szimpla konzol

Ismételje meg 4-szer.

4x

4

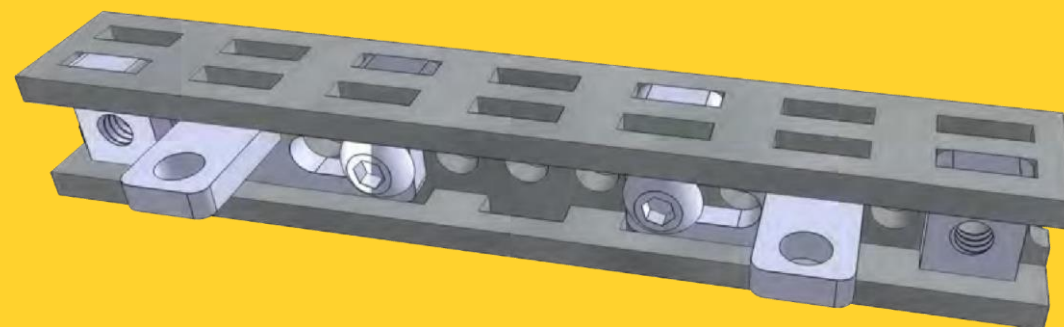
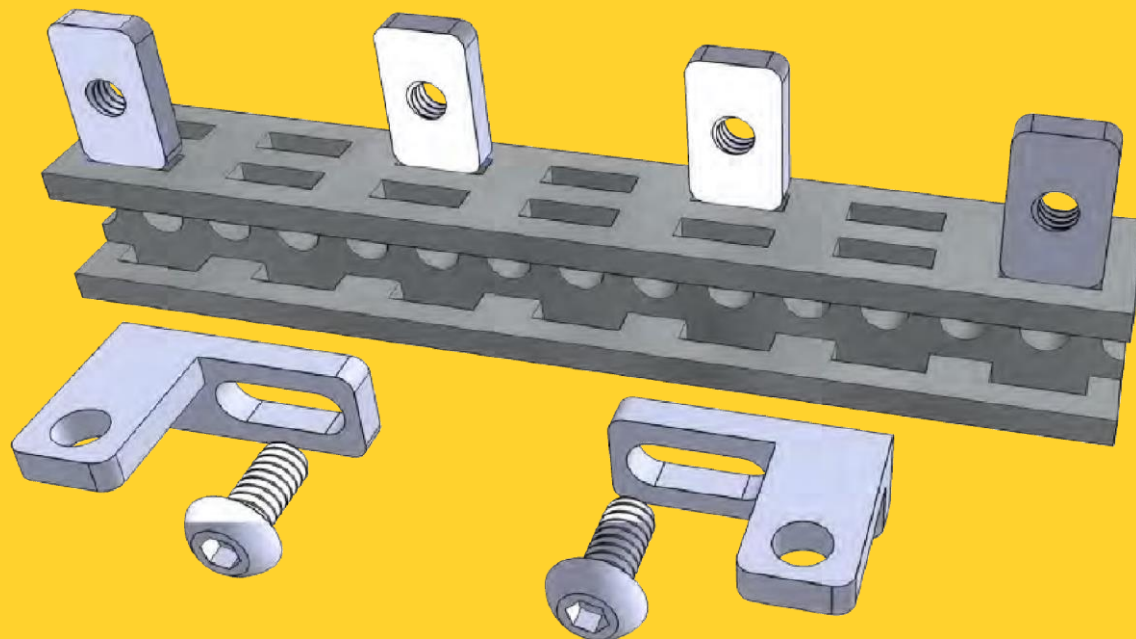

Ismételje meg 2-szer.

**2x**



5

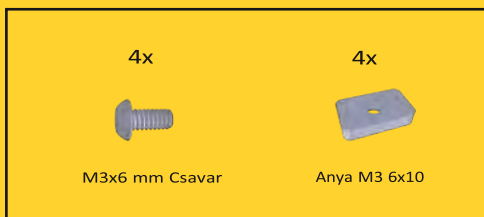
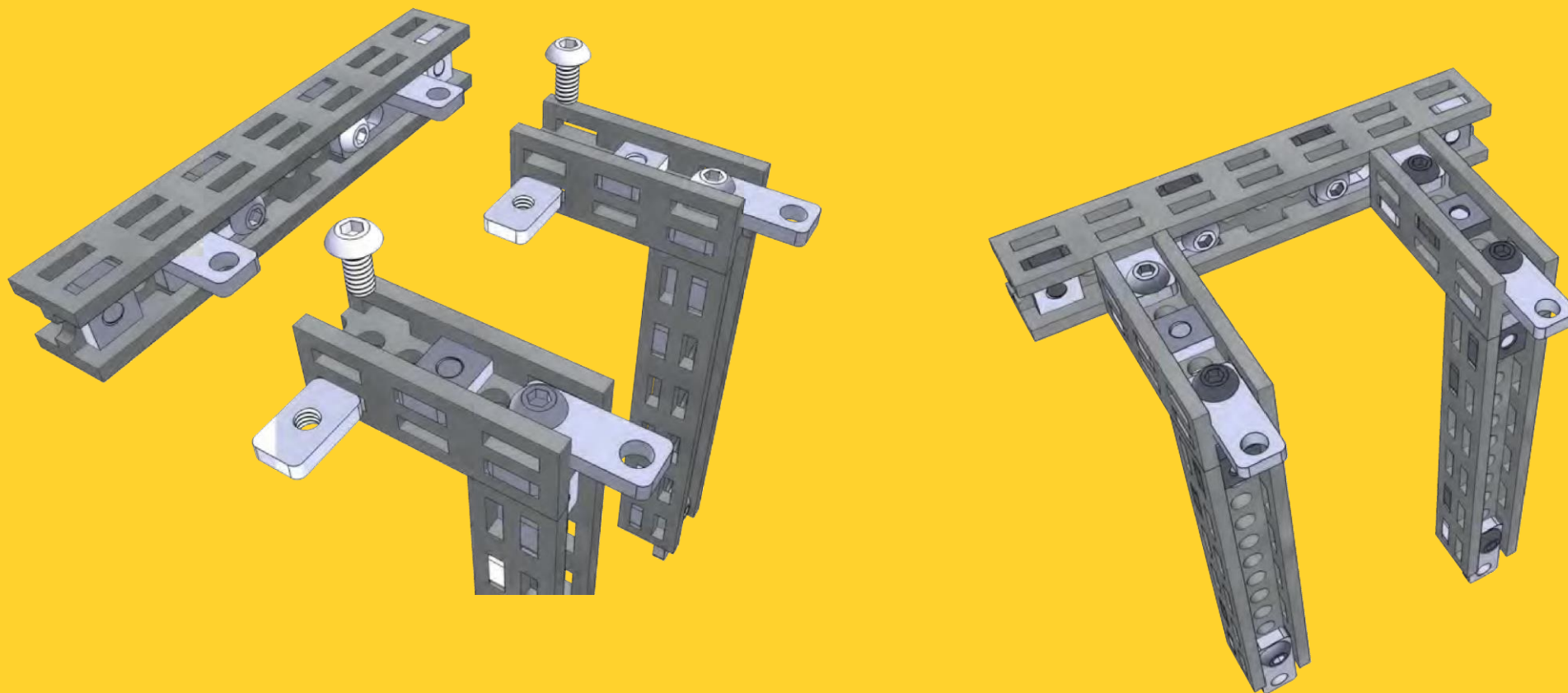

Ismételd meg 2-szer.

**2x**



**5.Rész**

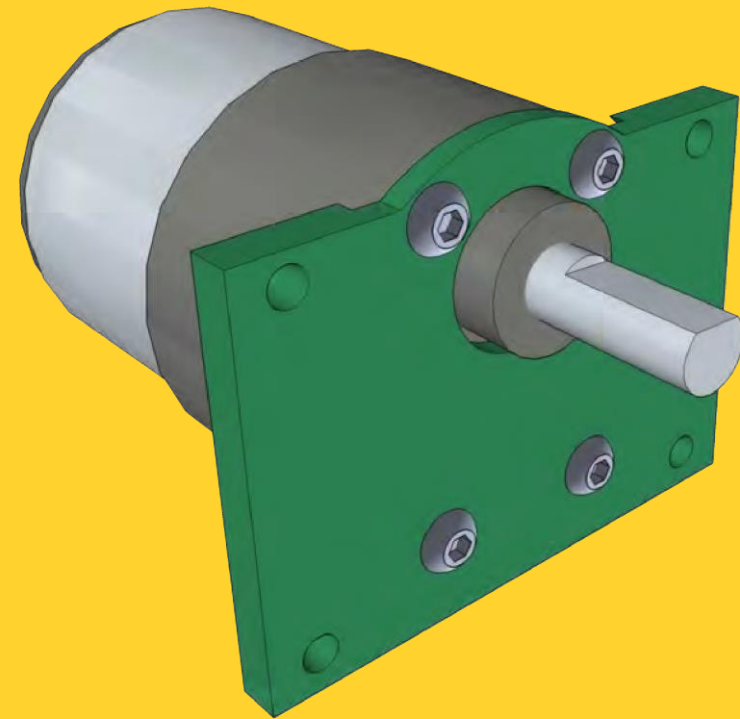
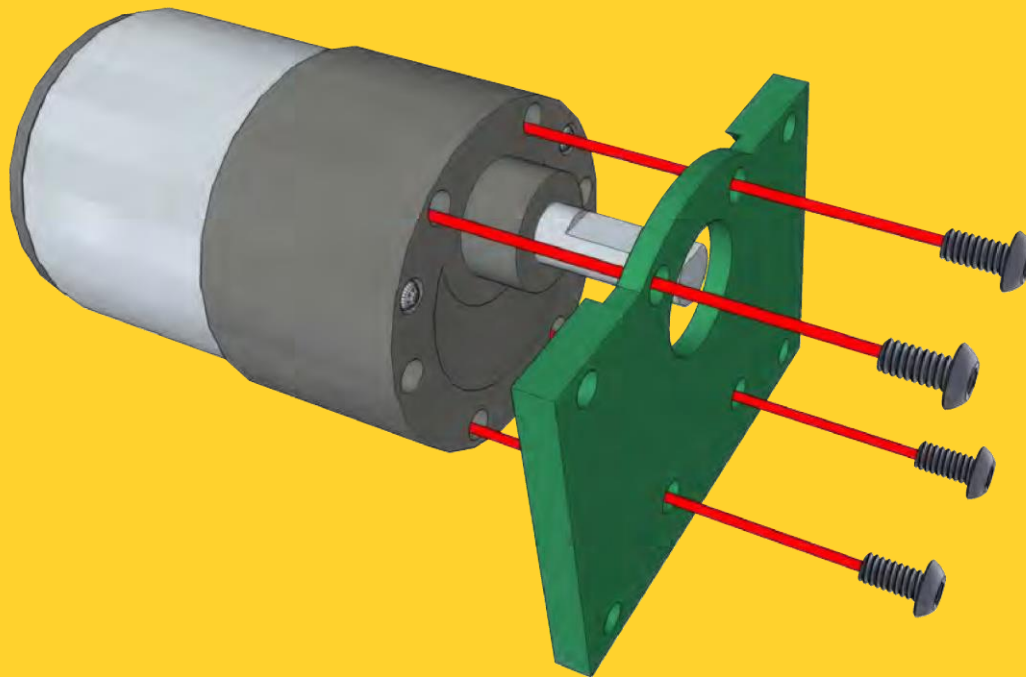

# 6.Rész

1



8x	2x	2x
		
M3x6 mm Csavar	Motor-lemez 37 mm	37 mm DC Motor

Ismételje meg 2-szer.

**2x**

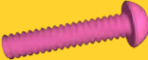

# 7. Rész

- 12x  
  
M3x6 mm Csavar
- 8x  
  
M3x14 mm Csavar

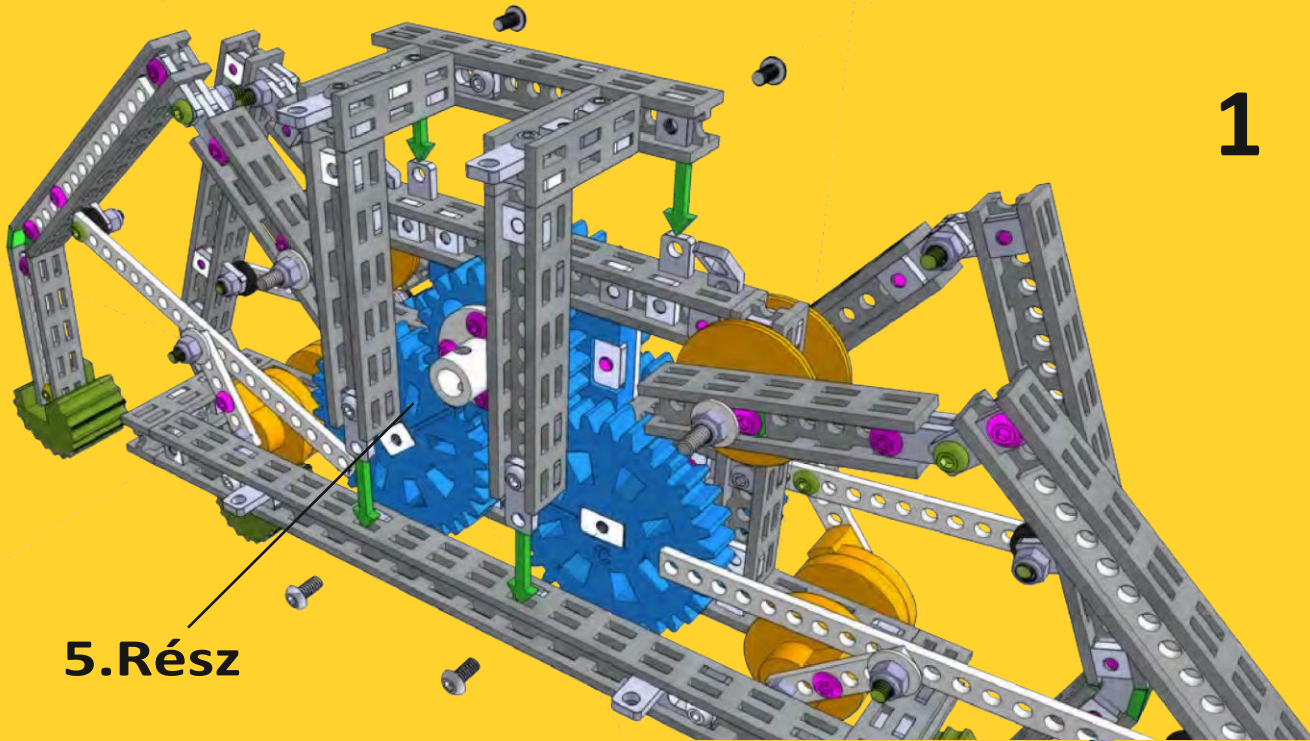

- 8x  
  
M3x6 mm Csavar

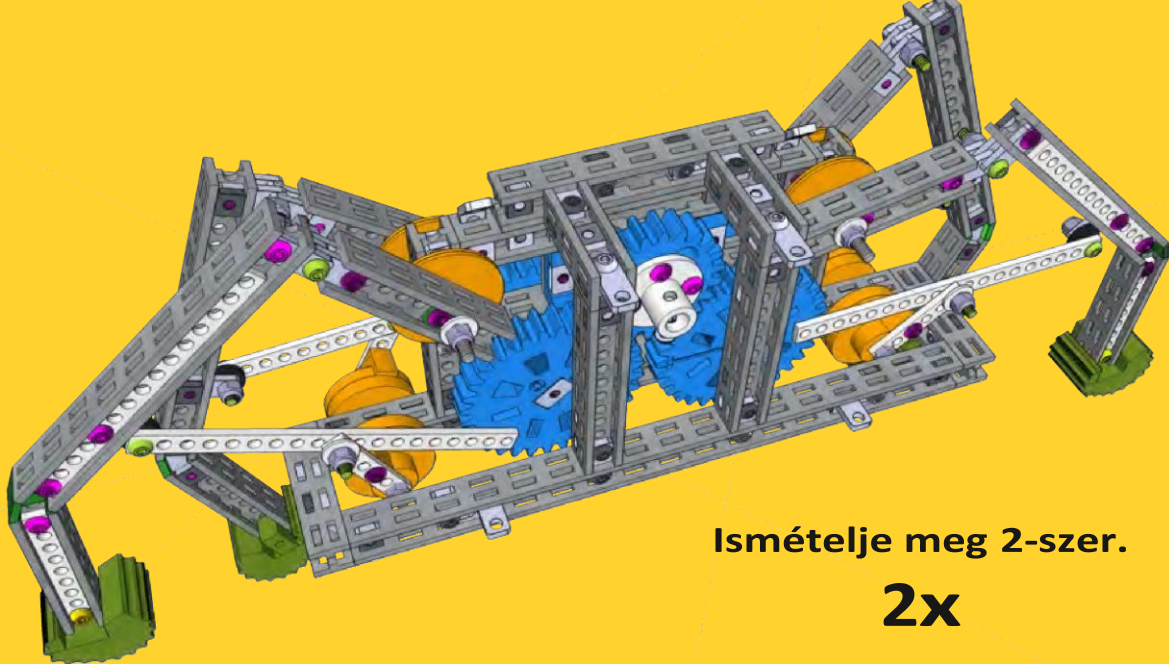

Ismételje meg 2-szer.

2x

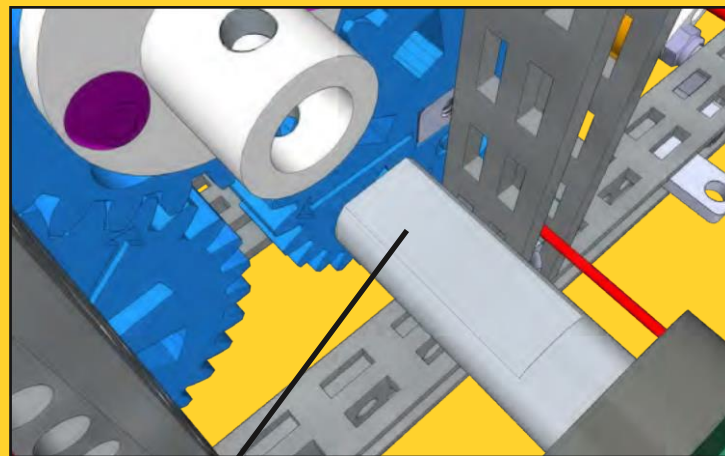
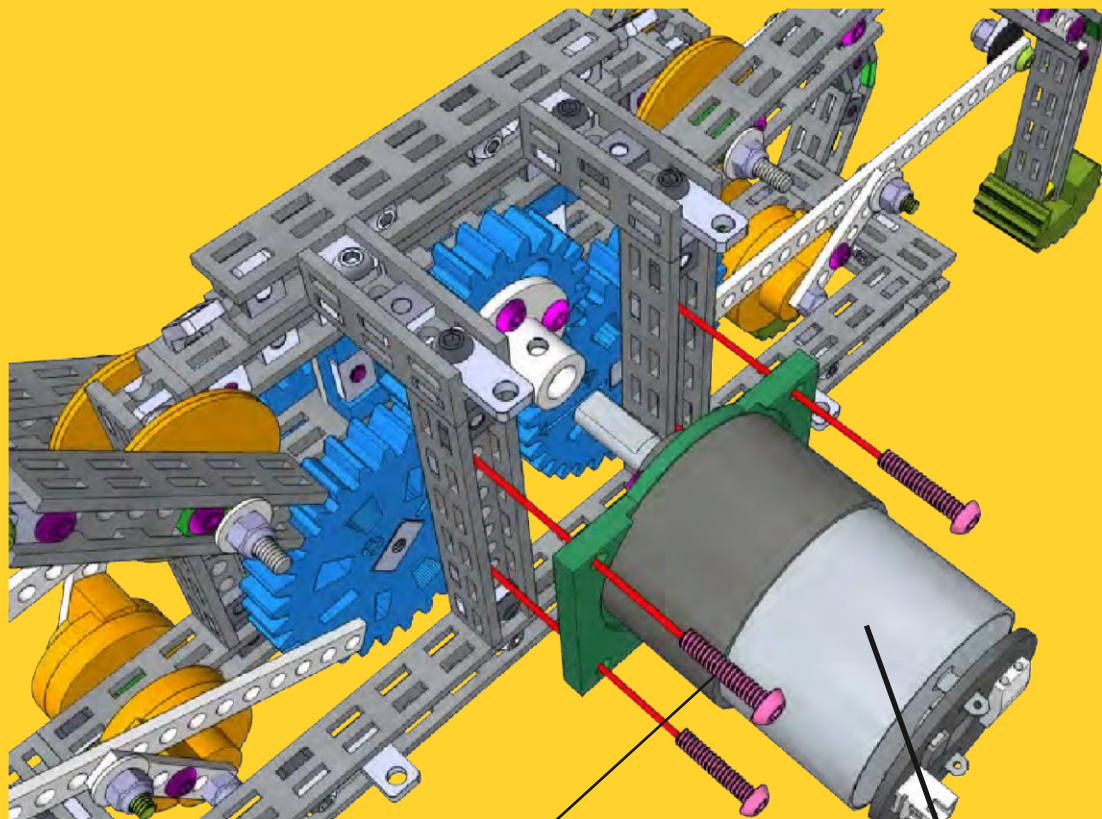

Lapos oldallal felfelé

6.Rész

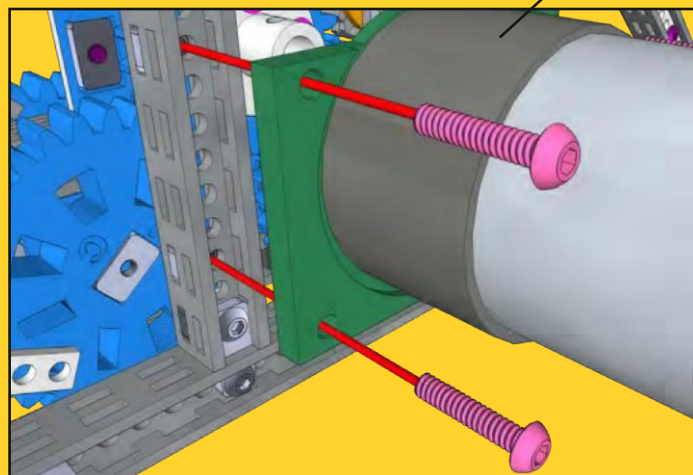

Ismételje meg 2-szer.

2x

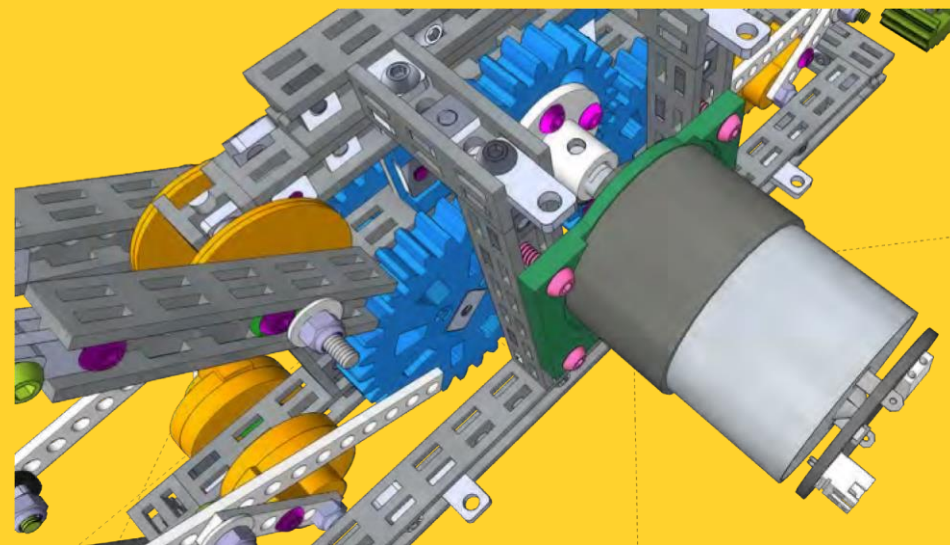
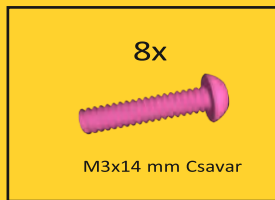



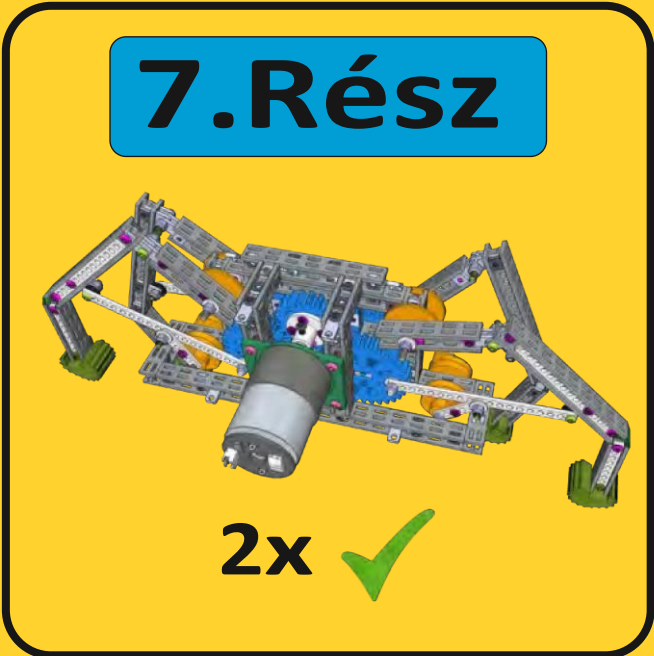
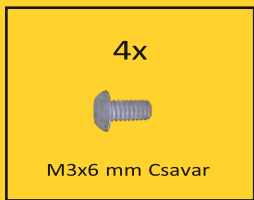
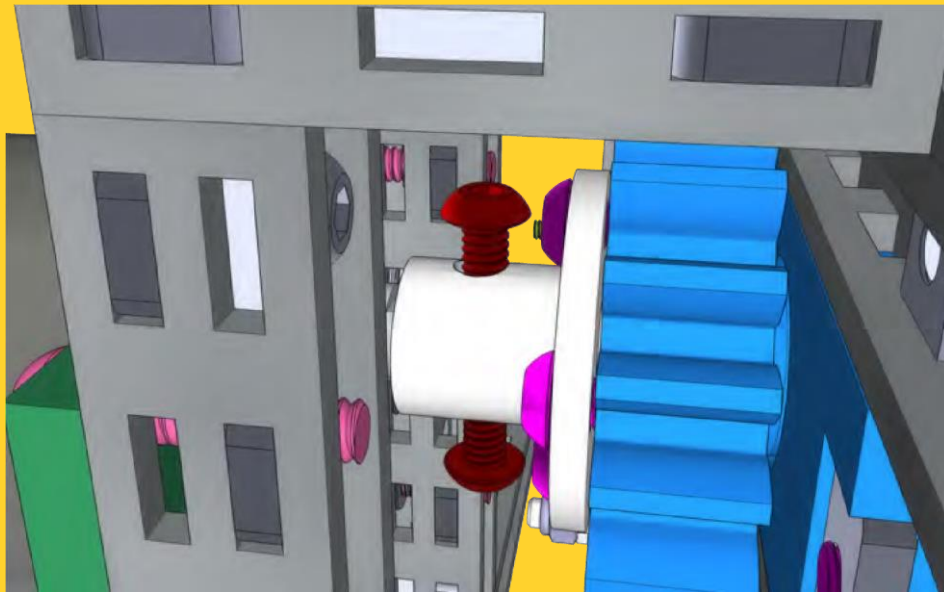
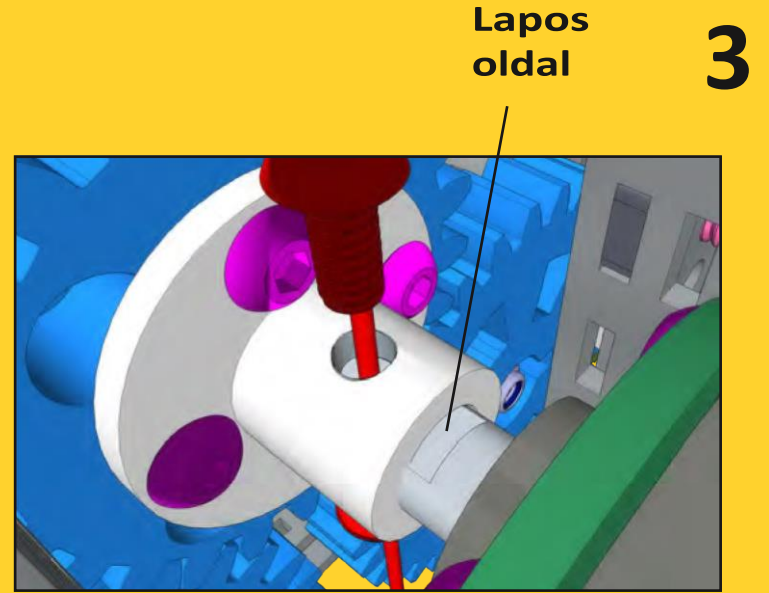
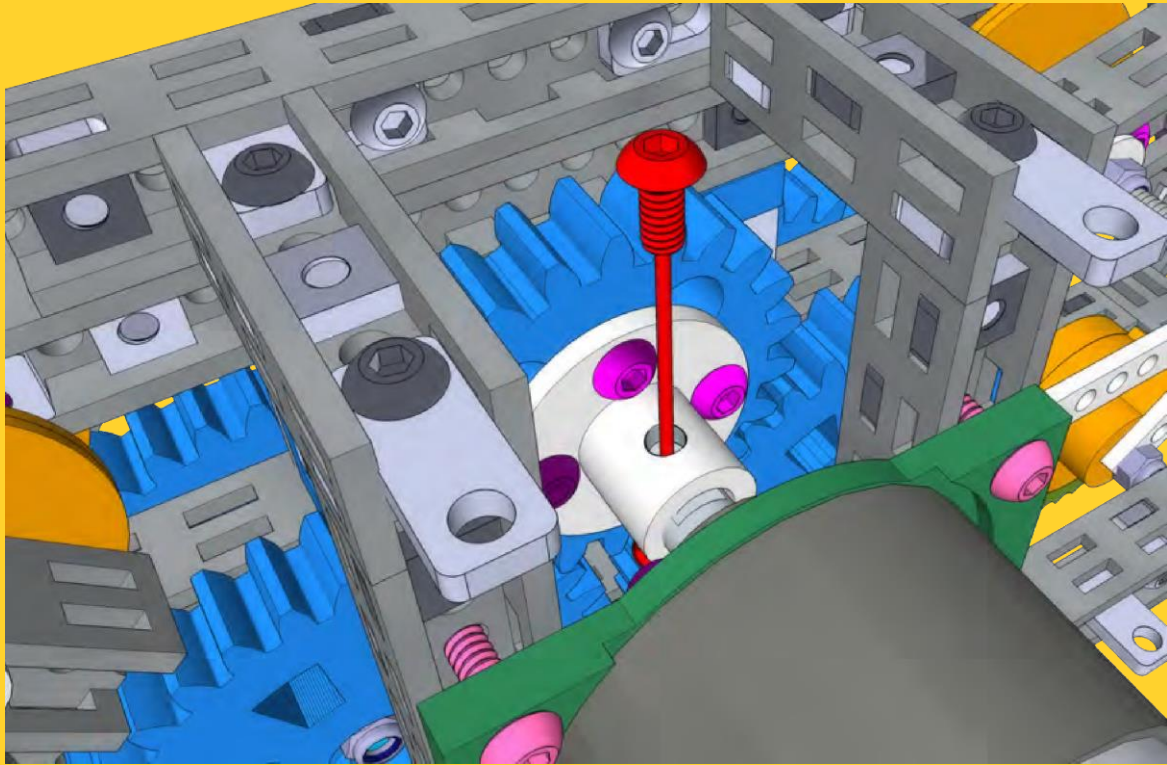



# 8. Rész

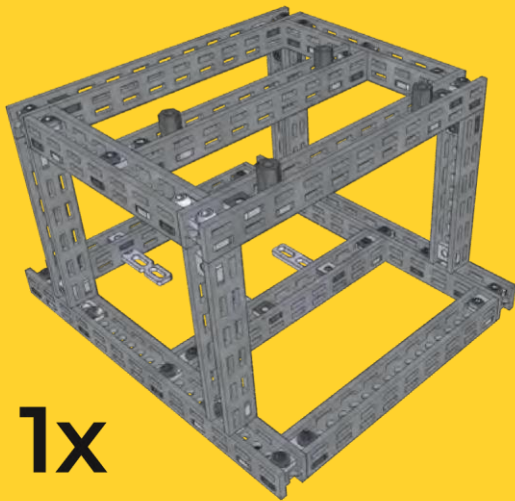

1x

44x M3x6mm Csavar	56x Anyá M3 6x10	12x 2-Lyukú Szimpla konzol
----------------------	---------------------	-------------------------------

4x C-Konzol	4x 3-Lyukú konzol	2x L-Csavart tükör konzol
----------------	----------------------	------------------------------

2x L-Csavart konzol	4x Műa.távtartó M3x8mm	4x 6cm Sín
------------------------	---------------------------	---------------

2x 7cm Sín	4x 9cm Sín	2x 11cm Sín
---------------	---------------	----------------

2x 13cm Sín
----------------

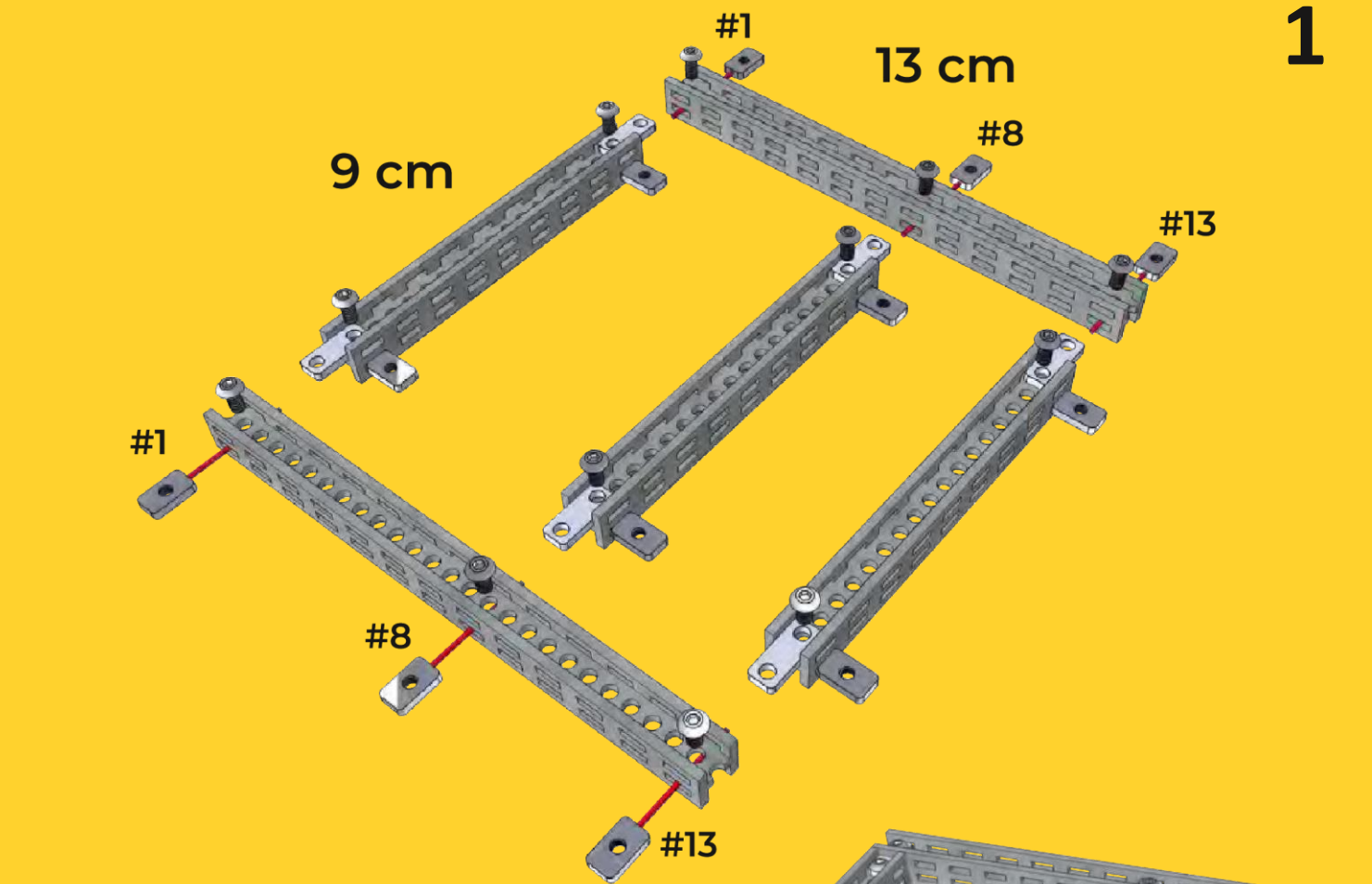

1

12x M3x6mm Csavar	12x Anyá M3 6x10	6x 2-Lyukú szimpla konzol
----------------------	---------------------	------------------------------

3x 9cm Sín	2x 13cm Sín
---------------	----------------

